

GF Piping Systems

+GF+

Product range FM approved 2019

Reliable to the extreme





Reliable to the extreme

Underground PE systems for fire protection



The Factory Mutual Research Corporation (FMRC) is the testing laboratory that is internationally recognized for its work testing components for fire protection systems. Components for fire protection systems are tested to ensure that the products can pass an aggressive level of performance, safety and quality standards. Any GF product that is labelled with the Factory Mutual <FM> symbol indicates that the product has met and even exceeded the rigorous requirements for fire protection systems. The manufacturing processes and the in-house testing facilities at GF have been inspected and approved by FMRC, and are audited frequently to ensure compliance and to promote continuing improvement.

Go beyond the core benefits of HDPE pipes

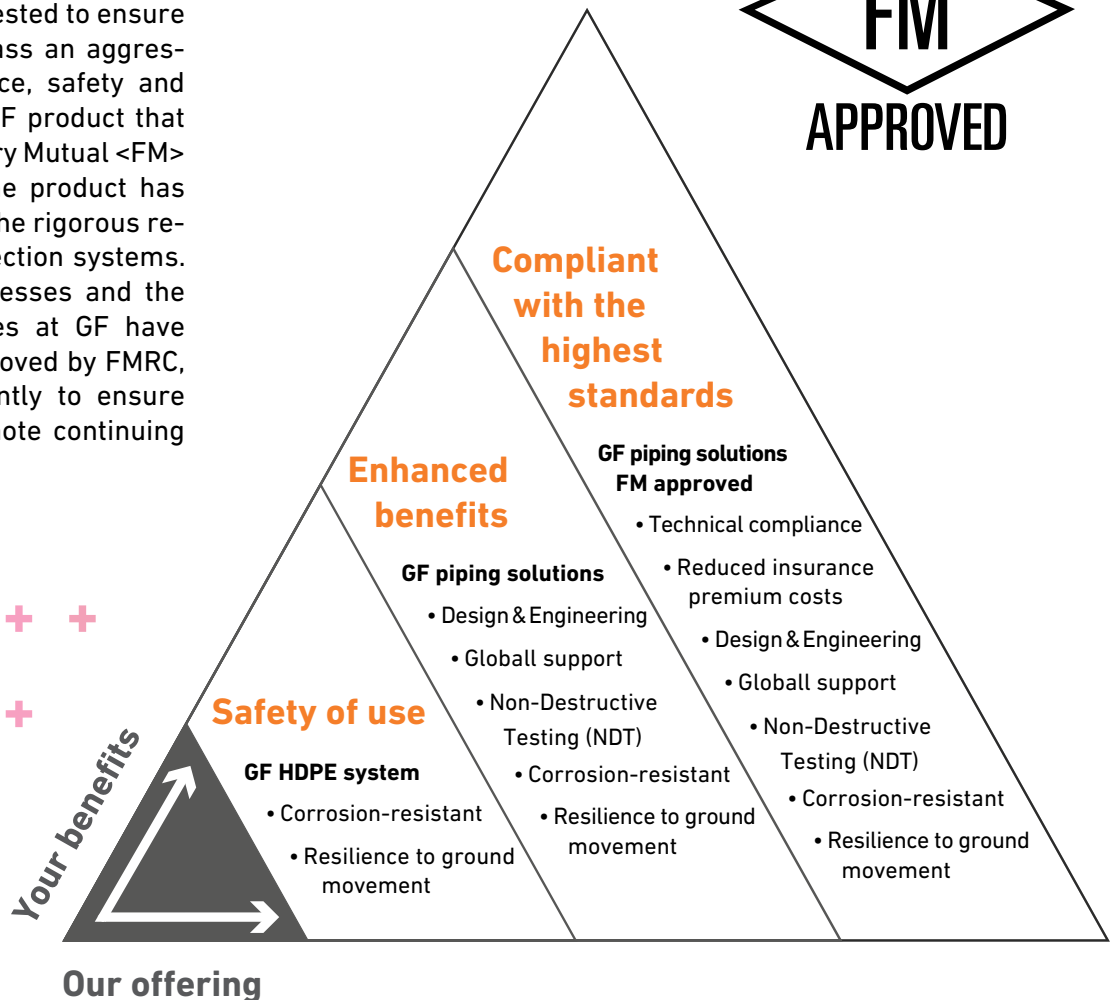
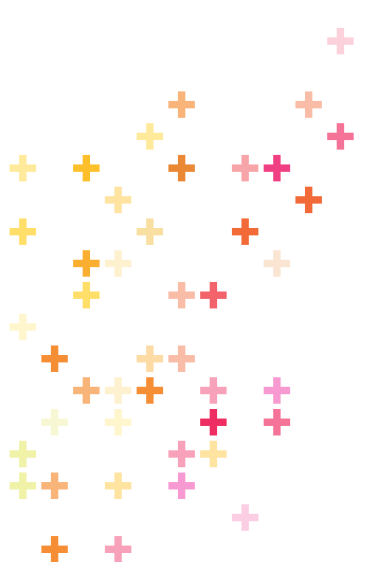

Overview of GF Indonesia products with FM-approval

+ Now the details



Product	FM Class SDR 11 13.8 bar (200 psi)	FM Class SDR 9 17.2 bar (250 psi)	FM Class SDR 7.4 21.7 bar (315 psi)
Pipe*	63 - 400 mm	63 - 400 mm	63 - 450 mm
Segmented Fittings			
Segmented Bend 45°	63 - 400 mm	63 - 400 mm	63 - 450 mm
Segmented Bend 90°	63 - 400 mm	63 - 400 mm	63 - 450 mm
RB Equal Tee	63 - 280 mm	63 - 280 mm	63 - 280 mm
Stub Flange	63 - 400 mm	63 - 400 mm	63 - 450 mm
Reducer Long Spigot	75x63mm, 90x75mm, 110x90mm, 125x110mm, 140x125mm, 160x140mm, 180x140mm 180x160mm, 200x180mm, 225x200mm, 250x225mm, 280x250mm, 315x280mm, 355x315mm, 400x355mm, 450x400mm	75x63mm, 90x75mm, 110x90mm, 125x110mm, 140x125mm, 160x140mm, 180x140mm 180x160mm, 200x180mm, 225x200mm, 250x225mm, 280x250mm, 315x280mm, 355x315mm, 400x355mm, 450x400mm	75x63mm, 90x75mm, 110x90mm, 125x110mm, 140x125mm, 160x140mm, 180x140mm 180x160mm, 200x180mm, 225x200mm, 250x225mm, 280x250mm, 315x280mm, 355x315mm, 400x355mm, 450x400mm

* Dimension refers to ISO 4427 - 2007 "Plastics piping system-Polyethylene(PE) pipes and fitting for water supply".
Pipe and fittings are connected by a Butt Weld and Electrofusion welding process only.
The manufacturer's Butt Weld and Electrofusion welding instructions must be strictly adhered to for a proper joint.

The technical data are not binding. They neither constitute expressly warranted characteristics nor guaranteed properties nor a guaranteed durability. They are subject to modification. Our General Terms of Sale apply.

For further information please get in touch with us
PT Georg Fischer Indonesia
T +62 267 432 044 F +62 267 431 857
indonesia.ps@georgfischer.com
www.gfps.com/id

Table of contents

Packaging, handling and storage	2
Pipe	3
PE Fittings (FM Approved)	5
Index	13

Packaging, handling and storage

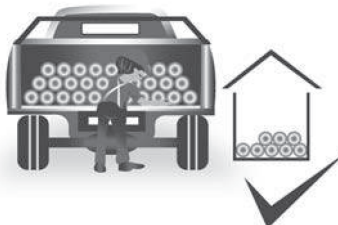
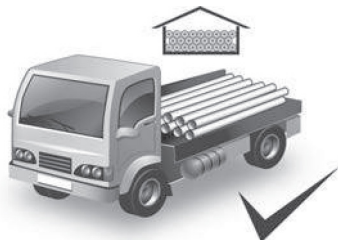
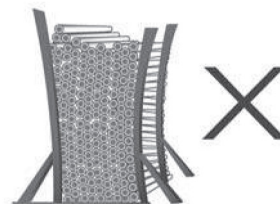
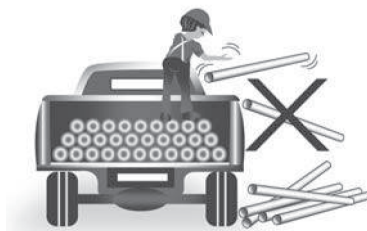

Polyethylene (PE) pipe is tough and resilient. However its relative lightness can be deceptive when considering the safety aspects of moving and handling. It can also be damaged by excessive scuffing or gouging of ends, external and internal surfaces during loading, unloading and transfer operations.

Transport

PE pipes should be transported on a flat-bed, container or curtain-side type vehicle, free from sharp objects and any projections. Care should be taken to ensure the size, shape, weight and centre of gravity are such that the stability and security of the load is not compromised throughout the transport journey. Furthermore, nothing should be placed on top of PE pipes during transport which could cause the pipe to deform.

Loading and Unloading

Wide slings should be used to lift pipe bundles by crane. Chains, hooks or wire rope slings should not be used since they can slip and gouge or abrade the pipe surface. Strapping or banding straps used to retain packs and bundles must not be used for lifting or handling. Allowance should be made for deflection or bending of pipes during all loading and unloading operations.

Depending on the terrain, standard forklifts can generally be used for lengths up to 6m. If a forklift is used, contact points must be protected from damage and forklift tines must not be inserted between the windings of the coils. Longer lengths should be lifted and moved by equipment fitted with loadspreading beams or attachments. Cranes or Hiabs can be efficient and safe provided precautions are made for correct slinging of the load and operation of the equipment. Larger diameter pipes (e.g. 355mm OD and over) should be handled individually. These are generally less stable than bundled lengths and will move freely unless adequately restrained.

Pipes which have been held or restrained in bundles or singly by strapping or banding etc. during storage, handling and transportation will hold considerable amounts of stored energy. Thermal expansion and contraction contributes to the amount and the direction of the stored energy. This stored energy can be hazardous if released incorrectly.

Storage

Pipe should not be stored in direct contact with the ground. Timber battens or other suitable means should be placed under the pipe in uniform spacing. Stack height should be limited to prevent pipe from losing shape due to imposed loads. Nothing should be placed on top of PE pipes during storage which could cause pipe to deform. Pipe stacks should be pegged, chocked or otherwise secured to prevent pipes rolling or falling.

Bundled packs should be stacked so that their packaging battens are in line with each other. This will facilitate easy access by the forklift truck or side loader. Where battens are not aligned additional rigid dunnage should be placed between bundles. Coils can be stored flat on a solid flat surface or in near vertical position to prevent distortion.

Impact, abrasion and contact with hot surfaces such as vehicle exhausts can damage pipes and pipe ends. Covered storage should be considered if prolonged exposure to direct sunlight is envisaged as well as storage away from sources of direct heat or fire. Pipe should not be stored where there is a possibility of contact with chemicals (e.g. lubricating/hydraulic oils, solvents, conditioning fluids etc). Pipe which has been heavily contaminated with such substances should be scrapped.

Pipe (FM Approved)

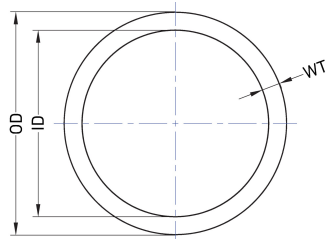

SDR11/13.6Bar (200Psi)

Model:

- Material: PE100

Code	OD (mm)	WT (Min.) (mm)	ID min. (mm)	Ave. Mass (kg/m)
P5416203063	63	5.8	51.00	1.07
P5416203075	75	6.8	60.95	1.49
P5416203090	90	8.2	73.05	2.16
P5416203110	110	10.0	89.40	3.20
P5416203125	125	11.4	101.50	4.15
P5416203140	140	12.7	113.85	5.17
P5416203160	160	14.6	129.95	6.79
P5416203180	180	16.4	146.25	8.58
P5416203200	200	18.2	162.50	10.58
P5416203225	225	20.5	182.85	13.39
P5416203250	250	22.7	203.35	16.47
P5416203280	280	25.4	227.80	20.64
P5416203315	315	28.6	256.25	26.13
P5416203355	355	32.2	288.80	33.16
P5416203400	400	36.3	325.40	42.11
P5416203450	450	40.9	366.05	53.32

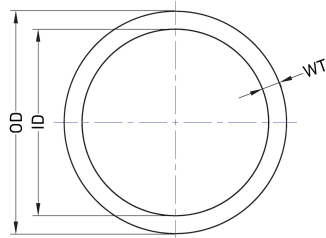

SDR9/17.2Bar (250Psi)

Model:

- Material: PE100

Code	OD (mm)	WT (Min.) (mm)	ID min. (mm)	Ave. Mass (kg/m)
P5417203063	63	7.1	48.20	1.28
P5417203075	75	8.4	57.55	1.79
P5417203090	90	10.1	69.05	2.59
P5417203110	110	12.3	84.50	3.84
P5417203125	125	14.0	96.10	4.96
P5417203140	140	15.7	107.55	6.23
P5417203160	160	17.9	123.05	8.11
P5417203180	180	20.1	138.45	10.26
P5417203200	200	22.4	153.70	12.69
P5417203225	225	25.2	173.15	16.01
P5417203250	250	27.9	192.45	19.74
P5417203280	280	31.3	215.40	24.81
P5417203315	315	35.2	242.35	31.38
P5417203355	355	39.7	273.30	39.77
P5417203400	400	44.7	307.80	50.55
P5417203450	450	50.3	346.45	63.91

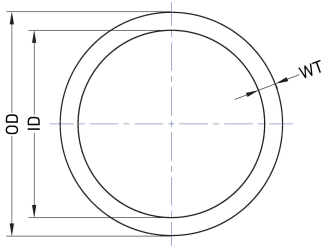

SDR7.4/21.7Bar (315Psi)

Model:

- Material: PE100

Code	OD (mm)	WT (Min.) (mm)	ID min. (mm)	Ave. Mass (kg/m)
P5418203063	63	8.6	45.10	1.50
P5418203075	75	10.3	53.55	2.13
P5418203090	90	12.3	64.45	3.05
P5418203110	110	15.1	78.60	4.57
P5418203125	125	17.1	89.50	5.89
P5418203140	140	19.2	100.15	7.39
P5418203160	160	21.9	114.65	9.62
P5418203180	180	24.6	129.05	12.17
P5418203200	200	27.4	143.40	15.00
P5418203225	225	30.8	161.25	19.02
P5418203250	250	34.2	179.15	23.48
P5418203280	280	38.3	200.70	29.44
P5418203315	315	43.1	226.05	37.17
P5418203355	355	48.5	254.60	47.25
P5418203400	400	54.7	287.00	59.93
P5418203450	450	61.5	322.75	75.93

PE Fittings (FM Approved)

Segmented Bend

Segmented bend 45°

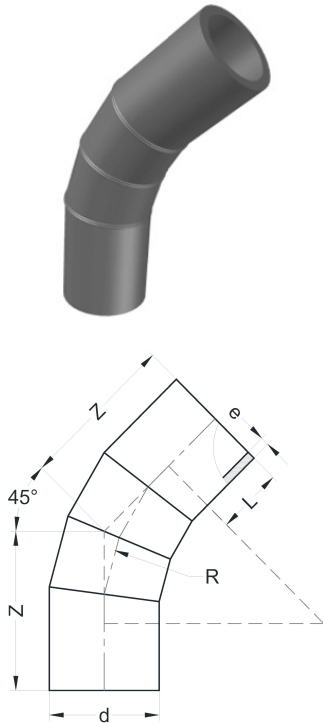

Segmented bend 45° SDR11 PN13.8 (200Psi)

- Material: PE100
- Model:**
- Non Derating

Code	Weight (kg)	d (mm)	Z (mm)	L (mm)	R (mm)	e (mm)
P5416605063	0.70	63	294	150	347.0	5.80
P5416605075	0.97	75	306	150	375.0	6.80
P5416605090	1.40	90	300	150	360.0	8.20
P5416605110	2.24	110	350	200	363.0	10.00
P5416605125	2.91	125	356	200	375.0	11.40
P5416605140	3.88	140	363	200	392.0	12.70
P5416605160	5.09	160	366	200	400.0	14.60
P5416605180	6.86	180	387	200	450.0	16.40
P5416605200	8.46	200	407	200	500.0	18.20
P5416605225	12.05	225	433	200	562.5	20.50
P5416605250	16.47	250	509	250	625.0	22.70
P5416605280	22.70	280	540	250	700.0	25.40
P5416605315	36.58	315	676	350	787.5	28.60
P5416605355	46.42	355	718	350	887.5	32.20
P5416605400	63.17	400	765	350	1000.0	36.30
P5416605450	85.31	450	816	350	1125.0	40.90

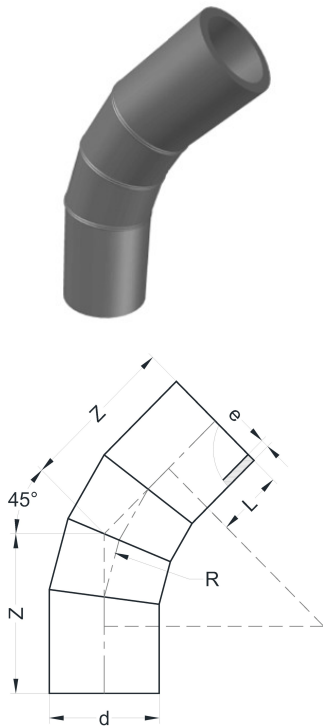

Segmented bend 45° SDR9 PN17.2 (250Psi)

- Material: PE100
- Model:**
- Non Derating

Code	Weight (kg)	Z (mm)	d (mm)	L (mm)	R (mm)	e (mm)
P5417605063	0.83	294	63	150	347.0	7.1
P5417605075	1.16	306	75	150	375.0	8.4
P5417605090	1.68	300	90	150	360.0	10.1
P5417605110	2.69	350	110	200	363.0	12.3
P5417605125	3.47	356	125	200	375.0	14.0
P5417605140	4.67	363	140	200	392.0	15.7
P5417605160	6.08	366	160	200	400.0	17.9
P5417605180	8.21	387	180	200	450.0	20.1
P5417605200	10.15	407	200	200	500.0	22.4
P5417605225	14.41	433	225	200	562.5	25.2
P5417605250	19.74	509	250	250	625.0	27.9
P5417605280	27.29	540	280	250	700.0	31.3
P5417605315	43.93	676	315	350	787.5	35.2
P5417605355	55.68	718	355	350	887.5	39.7
P5417605400	75.83	765	400	350	1000.0	44.7
P5417605450	102.26	816	450	350	1125.0	50.3

Segmented bend 45° SDR7.4 PN21.7 (315Psi)

- Material: PE100

Model:

- Non Derating

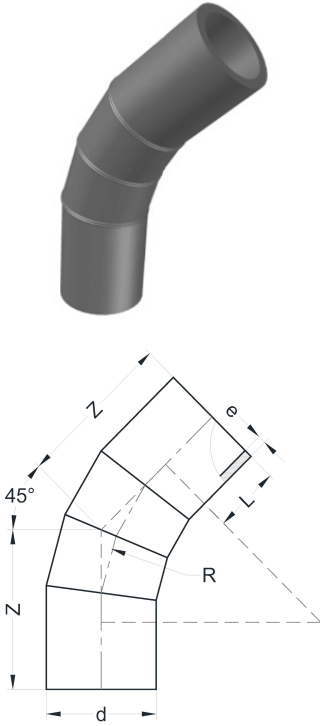

Code	Weight (kg)	d (mm)	Z (mm)	L (mm)	R (mm)	e (mm)
P5418605063	0.98	63	294	150	347.0	8.6
P5418605075	1.38	75	306	150	375.0	10.3
P5418605090	1.98	90	300	150	360.0	12.3
P5418605110	3.20	110	350	200	363.0	15.1
P5418605125	4.12	125	356	200	375.0	17.1
P5418605140	5.54	140	363	200	392.0	19.2
P5418605160	7.22	160	366	200	400.0	21.9
P5418605180	9.74	180	387	200	450.0	24.6
P5418605200	12.00	200	407	200	500.0	27.4
P5418605225	17.12	225	433	200	562.5	30.8
P5418605250	23.48	250	509	250	625.0	34.2
P5418605280	32.38	280	540	250	700.0	38.3
P5418605315	52.04	315	676	350	787.5	43.1
P5418605355	66.15	355	718	350	887.5	48.5
P5418605400	89.90	400	765	350	1000.0	54.7
P5418605450	121.49	450	816	350	1125.0	61.5

Segmented bend 90°

Segmented bend 90° SDR11 PN13.8 (200Psi)

- Material: PE100

Model:

- Non Derating

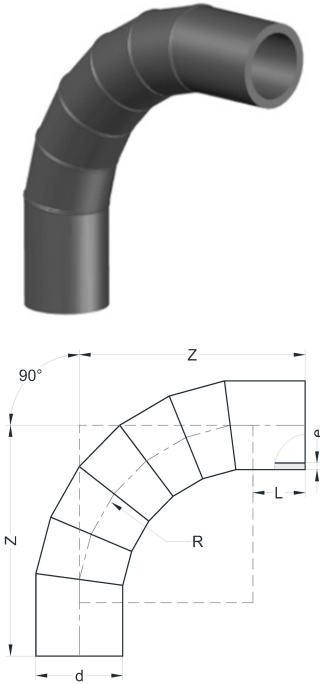

Code	Weight (kg)	d (mm)	Z (mm)	L (mm)	R (mm)	e (mm)
P5416607063	0.91	63	497	150	347.0	5.8
P5416607075	1.34	75	525	150	375.0	6.8
P5416607090	1.94	90	510	150	360.0	8.2
P5416607110	3.20	110	563	200	363.0	10.0
P5416607125	4.15	125	575	200	375.0	11.4
P5416607140	5.69	140	592	200	392.0	12.7
P5416607160	7.47	160	600	200	400.0	14.6
P5416607180	9.87	180	650	200	450.0	16.4
P5416607200	12.70	200	700	200	500.0	18.2
P5416607225	17.41	225	763	200	562.5	20.5
P5416607250	24.71	250	875	250	625.0	22.7
P5416607280	33.02	280	950	250	700.0	25.4
P5416607315	52.26	315	1138	350	787.5	28.6
P5416607355	69.64	355	1238	350	887.5	32.2
P5416607400	96.85	400	1350	350	1000.0	36.3
P5416607450	133.30	450	1475	350	1125.0	40.9

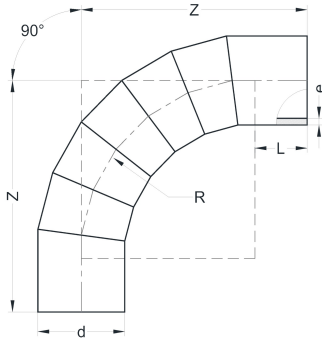

Segmented bend 90° SDR9 PN17.2 (250Psi)

- Material: PE100

Model:

- Non Derating

Code	Weight (kg)	d (mm)	Z (mm)	L (mm)	R (mm)	e (mm)
P5417607063	1.09	63	497	150	347	7.1
P5417607075	1.61	75	525	150	375	8.4
P5417607090	2.33	90	510	150	360	10.1
P5417607110	3.84	110	563	200	363	12.3
P5417607125	4.96	125	575	200	375	14.0
P5417607140	6.85	140	592	200	392	15.7
P5417607170	8.92	160	600	200	400	17.9
P5417607180	11.80	180	650	200	450	20.1
P5417607200	15.23	200	700	200	500	22.4
P5417607225	20.81	225	763	200	563	25.2
P5417607250	29.61	250	875	250	625	27.9
P5417607280	39.70	280	950	250	700	31.3
P5417607315	62.76	315	1138	350	788	35.2
P5417607355	83.52	355	1238	350	888	39.7
P5417607400	116.27	400	1350	350	1000	44.7
P5417607450	159.78	450	1475	350	1125	50.3

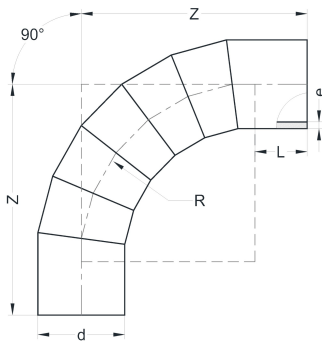

Segmented bend 90° SDR7.4 PN21.7 (315Psi)

- Material: PE100

Model:

- Non Derating

Code	Weight (kg)	d (mm)	Z (mm)	L (mm)	R (mm)	e (mm)
P5418607063	1.280	63	497	150	347.0	8.6
P5418607075	1.920	75	525	150	375.0	10.3
P5418607090	2.750	90	510	150	360.0	12.3
P5418607110	4.570	110	563	200	363.0	15.1
P5418607125	5.890	125	575	200	375.0	17.1
P5418607140	8.130	140	592	200	392.0	19.2
P5418607180	14.000	160	650	200	400.0	24.6
P5418607180	14.000	160	650	200	400.0	24.6
P5418607200	18.000	200	700	200	500.0	27.4
P5418607225	24.730	225	763	200	562.5	30.8
P5418607250	35.220	250	875	250	625.0	34.2
P5418607280	47.100	280	950	250	700.0	38.3
P5418607315	74.340	315	1138	350	787.5	43.1
P5418607355	99.230	355	1238	350	887.5	48.5
P5418607400	137.840	400	1350	350	1000.0	54.7
P5418607450	189.830	450	1475	350	1125.0	61.5

Reinforced Branch Tee Equal

SDR11/13.8 Bar (200Psi)



Model:

- Material: PE100

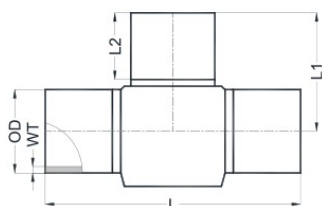

Code	OD (mm)	L (mm)	L1 (mm)	L2 (mm)	WT (Min.) (mm)
P5416123063	63	428	207	160	5.8
P5416123075	75	440	212	160	6.8
P5416123090	90	470	226	160	8.2
P5416123110	110	530	257	180	10.0
P5416123125	125	546	264	180	11.4
P5416123140	140	560	270	180	12.7
P5416123160	160	590	284	180	14.6
P5416123180	180	610	294	180	16.4
P5416123200	200	650	308	180	18.2
P5416123225	225	670	320	180	20.5
P5416123250	250	850	408	250	22.7
P5416123280	280	886	424	250	25.4

SDR9/17.2 Bar (250Psi)



Model:

- Material: PE 100

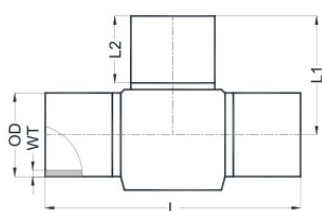

Code	OD (mm)	L (mm)	L1 (mm)	L2 (mm)	WT (Min.) (mm)
P5417123063	63	428	207	160	7.1
P5417123075	75	440	212	160	8.4
P5417123090	90	470	226	160	10.1
P5417123110	110	530	257	180	12.3
P5417123125	125	546	264	180	14.0
P5417123140	140	560	270	180	15.7
P5417123160	160	590	284	180	17.9
P5417123180	180	610	294	180	20.1
P5417123200	200	650	308	180	22.4
P5417123225	225	670	320	180	25.2
P5417123250	250	850	408	250	27.9
P5417123280	280	886	424	250	31.3

SDR7.4/21.7 Bar (315Psi)



Model:

- Material: PE 100

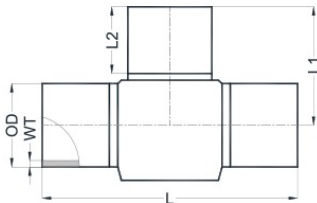

Code	OD (mm)	L (mm)	L1 (mm)	L2 (mm)	WT (Min.) (mm)
P5418123063	63	428	207	160	8.6
P5418123075	75	440	212	160	10.3
P5418123090	90	470	226	160	12.3
P5418123110	110	530	257	180	15.1
P5418123125	125	546	264	180	17.1
P5418123140	140	560	270	180	19.2
P5418123160	160	590	284	180	21.9
P5418123180	180	610	294	180	24.6
P5418123200	200	650	308	180	27.4
P5418123225	225	670	320	180	30.8
P5418123250	250	850	408	250	34.2
P5418123280	280	886	424	250	38.3

Reducer

Reducer long spigot

Reducer long spigot SDR11

- Long spigot version
- FM approved in combination with electro fusion

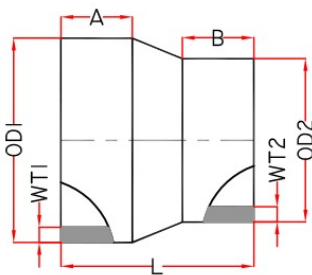

Code	Size	OD1 (mm)	OD2 (mm)	L (mm)	A (mm)	B (mm)	WT1 (mm)	WT2 (mm)
P5416111076	75 x 63	75	63	250	110	110	6.8	5.8
P5416111091	90 x 75	90	75	260	120	110	8.2	6.8
P5416111111	110 x 90	110	90	270	120	120	10.0	8.2
P5416111126	125 x 110	125	110	280	130	120	11.4	10.0
P5416111141	140 x 125	140	125	310	150	130	12.7	11.4
P5416111161	160 x 140	160	140	330	150	150	14.6	12.7
P5416111182	180 x 140	180	140	330	150	150	16.4	12.7
P5416111181	180 x 160	180	160	330	150	150	16.4	14.6
P5416111201	200 x 180	200	180	330	150	150	18.2	16.4
P5416111226	225 x 180	225	180	340	160	150	20.5	18.2
P5416111251	250 x 225	250	225	320	160	160	22.7	20.5
P5416111281	280 x 250	280	250	320	160	160	25.4	22.7
P5416111316	315 x 280	315	280	340	180	160	28.6	25.4
P5416111351	355 x 315	355	315	360	180	180	32.2	28.6
P5416111401	400 x 355	400	355	380	200	180	36.3	32.2
P5416111451	450 x 400	450	400	400	200	200	40.9	36.3

Reducer long spigot SDR9



- Long spigot version
- FM approved in combination with electro fusion

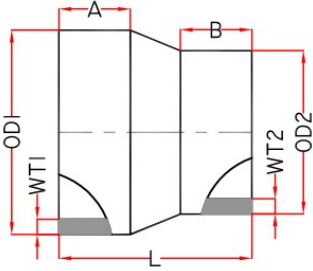

Code	Size (mm)	OD1 (mm)	OD2 (mm)	L (mm)	A (mm)	B (mm)	WT1 (mm)	WT2 (mm)
P5417111076	75 x 63	75	63	250	110	110	8.4	7.1
P5417111091	90 x 75	90	75	260	120	110	10.1	8.4
P5417111111	110 x 90	110	90	270	120	120	12.3	10.1
P5417111126	125 x 110	125	110	280	130	120	14.0	12.3
P5417111141	140 x 125	140	125	310	150	130	15.7	14.0
P5417111161	160 x 140	160	140	330	150	150	17.9	15.7
P5417111182	180 x 140	180	140	330	150	150	20.1	15.7
P5417111181	180 x 160	180	160	330	150	150	20.1	17.9
P5417111201	200 x 180	200	180	330	150	150	22.4	20.1
P5417111226	225 x 200	225	200	340	160	150	25.2	22.4
P5417111251	250 x 225	250	225	350	160	160	27.9	35.2
P5417111281	280 x 250	280	250	350	160	160	31.3	27.9
P5417111316	315 x 280	315	280	370	180	160	35.2	31.3
P5417111351	355 x 315	355	315	390	180	180	39.7	35.2
P5417111401	400 x 355	400	355	410	200	180	44.7	39.7
P5417111451	450 x 400	450	400	430	200	200	50.3	44.7

Reducer long spigot SDR 7.4



- Long spigot version
- FM approved in combination with electro fusion

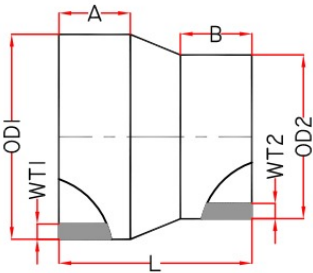

Code	Size (mm)	OD1 (mm)	OD2 (mm)	L (mm)	A (mm)	B (mm)	WT1 (mm)	WT2 (mm)
P5418111076	75 x 63	75	63	220	110	110	10.3	8.6
P5418111091	90 x 75	90	75	230	120	110	12.3	10.3
P5418111111	110 x 90	110	90	240	120	120	15.1	12.3
P5418111126	125 x 110	125	110	250	130	120	17.1	15.1
P5418111141	140 x 125	140	125	280	150	130	19.2	17.1
P5418111161	160 x 140	160	140	300	150	150	21.9	19.2
P5418111182	180 x 140	180	140	300	150	150	24.6	19.2
P5418111181	180 x 160	180	160	300	150	150	24.6	21.9
P5418111201	200 x 180	200	180	300	150	150	27.4	24.6
P5418111226	225 x 200	225	200	310	160	150	30.8	27.4
P5418111251	250 x 225	250	225	320	160	160	34.2	30.8
P5418111281	280 x 250	280	250	320	160	160	38.3	34.2
P5418111316	315 x 280	315	280	340	180	160	43.1	38.3
P5418111351	355 x 315	355	315	360	180	180	48.5	43.1
P5418111401	400 x 355	400	355	380	200	180	54.7	48.5
P5418111451	450 x 400	450	400	400	200	200	61.5	54.7

Stub flange

Stub flange long spigot

Stub flange long spigot SDR11/13.8 Bar (200Psi)

- Material: PE100

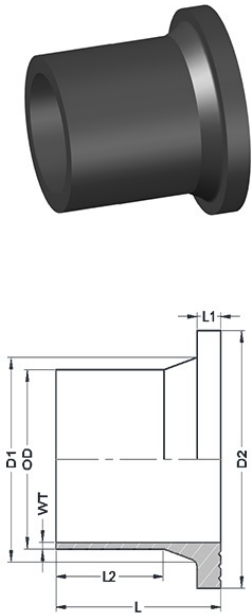

Code	Weight (kg)	OD (mm)	D1 (mm)	D2 (mm)	L (mm)	L1 (mm)	L2 (mm)	WT (Min.) (mm)
P5416137063	0.27	63	75	94	160	25	110	5.80
P5416137075	0.35	75	88	107	160	25	110	6.80
P5416137090	0.56	90	103	126	175	30	120	8.20
P5416137110	0.82	110	124	154	175	30	120	10.00
P5416137125	1.03	125	132	154	195	40	130	11.40
P5416137140	1.52	140	151	185	215	40	150	12.70
P5416137160	1.97	160	168	210	215	40	150	14.60
P5416137180	2.13	180	189	210	215	40	150	16.40
P5416137200	3.50	200	225	262	230	50	150	18.20
P5416137225	3.84	225	235	265	240	50	160	20.50
P5416137250	6.00	250	284	323	250	60	160	22.70
P5416137280	6.17	280	294	323	250	60	160	25.40
P5416137315	8.79	315	335	373	275	60	180	28.60
P5416137355	11.65	355	366	418	290	65	180	32.20
P5416137400	17.11	400	420	481	320	75	200	36.30
P5416137450	21.58	450	470	536	325	75	200	40.90

Stub flange long spigot SDR9/17.2 Bar (250Psi)

- Material: PE100

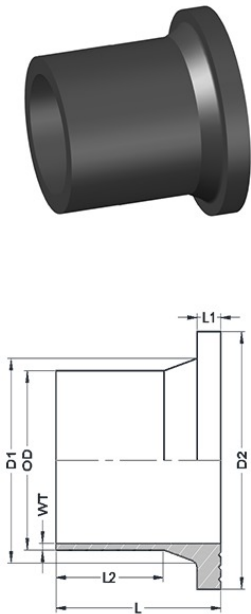

Code	Weight (kg)	OD (mm)	D1 (mm)	D2 (mm)	L (mm)	L1 (mm)	L2 (mm)	WT (Min.) (mm)
P5417137063	0.30	63	75	94	160	25	110	7.10
P5417137075	0.40	75	88	107	160	25	110	8.40
P5417137090	0.63	90	103	126	175	30	120	10.10
P5417137110	0.93	110	124	154	175	30	120	12.30
P5417137125	1.18	125	132	154	195	40	130	14.00
P5417137140	1.74	140	151	185	215	40	150	15.70
P5417137160	2.24	160	168	210	215	40	150	17.90
P5417137180	2.48	180	189	210	215	40	150	20.10
P5417137200	3.97	200	225	262	230	50	150	22.40
P5417137225	4.45	225	235	265	240	50	160	25.20
P5417137250	6.78	250	284	323	250	60	160	27.90
P5417137280	7.16	280	294	323	250	60	160	31.30
P5417137315	10.17	315	335	373	275	60	180	35.20
P5417137355	13.52	355	366	418	290	65	180	39.70
P5417137400	19.71	400	420	481	320	75	200	44.70
P5417137450	24.91	450	470	536	325	75	200	50.30

Stub flange long spigot SDR7.4 / 21.7 Bar (315Psi)

- Material: PE100

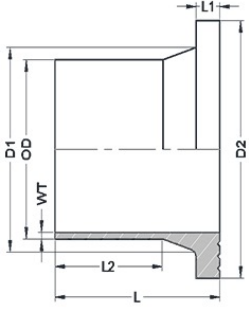

Code	Weight (kg)	OD (mm)	D1 (mm)	D2 (mm)	L (mm)	L1 (mm)	L2 (mm)	WT (Min.) (mm)
P5418137063	0.33	63	75	94	160	25	110	8.60
P5418137075	0.45	75	88	107	160	25	110	10.30
P5418137090	0.71	90	103	126	175	30	120	12.30
P5418137110	1.10	110	124	154	175	30	120	15.10
P5418137125	1.35	125	132	154	195	40	130	17.10
P5418137140	1.98	140	151	185	215	40	150	19.20
P5418137160	2.55	160	168	210	215	40	150	21.90
P5418137180	2.87	180	189	210	215	40	150	24.60
P5418137200	4.49	200	225	262	230	50	150	27.40
P5418137225	5.14	225	235	265	240	50	160	30.80
P5418137250	7.68	250	284	323	250	60	160	34.20
P5418137280	8.28	280	294	323	250	60	160	38.30
P5418137315	11.73	315	335	373	275	60	180	43.10
P5418137355	15.58	355	366	418	290	65	180	48.50
P5418137400	22.63	400	420	481	320	75	200	54.70
P5418137450	28.64	450	470	536	325	75	200	61.50

Index

Code	Page	Code	Page	Code	Page	Code	Page
P5416111076	9	P5416605090	5	P5417137125	11	P5418111111	10
P5416111091	9	P5416605110	5	P5417137140	11	P5418111126	10
P5416111111	9	P5416605125	5	P5417137160	11	P5418111141	10
P5416111126	9	P5416605140	5	P5417137180	11	P5418111161	10
P5416111141	9	P5416605160	5	P5417137200	11	P5418111181	10
P5416111161	9	P5416605180	5	P5417137225	11	P5418111182	10
P5416111181	9	P5416605200	5	P5417137250	11	P5418111201	10
P5416111182	9	P5416605225	5	P5417137280	11	P5418111226	10
P5416111201	9	P5416605250	5	P5417137315	11	P5418111251	10
P5416111226	9	P5416605280	5	P5417137355	11	P5418111281	10
P5416111251	9	P5416605315	5	P5417137400	11	P5418111316	10
P5416111281	9	P5416605355	5	P5417137450	11	P5418111351	10
P5416111316	9	P5416605400	5	P5417203063	3	P5418111401	10
P5416111351	9	P5416605450	5	P5417203075	3	P5418111451	10
P5416111401	9	P5416607063	6	P5417203090	3	P5418123063	9
P5416111451	9	P5416607075	6	P5417203110	3	P5418123075	9
P5416123063	8	P5416607090	6	P5417203125	3	P5418123090	9
P5416123075	8	P5416607110	6	P5417203140	3	P5418123110	9
P5416123090	8	P5416607125	6	P5417203160	3	P5418123125	9
P5416123110	8	P5416607140	6	P5417203180	3	P5418123140	9
P5416123125	8	P5416607160	6	P5417203200	3	P5418123160	9
P5416123140	8	P5416607180	6	P5417203225	3	P5418123180	9
P5416123160	8	P5416607200	6	P5417203250	3	P5418123200	9
P5416123180	8	P5416607225	6	P5417203280	3	P5418123225	9
P5416123200	8	P5416607250	6	P5417203315	3	P5418123250	9
P5416123225	8	P5416607280	6	P5417203355	3	P5418123280	9
P5416123250	8	P5416607315	6	P5417203400	3	P5418137063	12
P5416123280	8	P5416607355	6	P5417203450	3	P5418137075	12
P5416137063	11	P5416607400	6	P5417605063	5	P5418137090	12
P5416137075	11	P5416607450	6	P5417605075	5	P5418137110	12
P5416137090	11	P5417111076	10	P5417605090	5	P5418137125	12
P5416137110	11	P5417111091	10	P5417605110	5	P5418137140	12
P5416137125	11	P5417111111	10	P5417605125	5	P5418137160	12
P5416137140	11	P5417111126	10	P5417605140	5	P5418137180	12
P5416137160	11	P5417111141	10	P5417605160	5	P5418137200	12
P5416137180	11	P5417111161	10	P5417605180	5	P5418137225	12
P5416137200	11	P5417111181	10	P5417605200	5	P5418137250	12
P5416137225	11	P5417111182	10	P5417605225	5	P5418137280	12
P5416137250	11	P5417111201	10	P5417605250	5	P5418137315	12
P5416137280	11	P5417111226	10	P5417605280	5	P5418137355	12
P5416137315	11	P5417111251	10	P5417605315	5	P5418137400	12
P5416137355	11	P5417111281	10	P5417605355	5	P5418137450	12
P5416137400	11	P5417111316	10	P5417605400	5	P5418203063	4
P5416137450	11	P5417111351	10	P5417605450	5	P5418203075	4
P5416203063	3	P5417111401	10	P5417607063	7	P5418203090	4
P5416203075	3	P5417111451	10	P5417607075	7	P5418203110	4
P5416203090	3	P5417123063	8	P5417607090	7	P5418203125	4
P5416203110	3	P5417123075	8	P5417607110	7	P5418203140	4
P5416203125	3	P5417123090	8	P5417607125	7	P5418203160	4
P5416203140	3	P5417123110	8	P5417607140	7	P5418203180	4
P5416203160	3	P5417123125	8	P5417607170	7	P5418203200	4
P5416203180	3	P5417123140	8	P5417607180	7	P5418203225	4
P5416203200	3	P5417123160	8	P5417607200	7	P5418203250	4
P5416203225	3	P5417123180	8	P5417607225	7	P5418203280	4
P5416203250	3	P5417123200	8	P5417607250	7	P5418203315	4
P5416203280	3	P5417123225	8	P5417607280	7	P5418203355	4
P5416203315	3	P5417123250	8	P5417607315	7	P5418203400	4
P5416203355	3	P5417123280	8	P5417607355	7	P5418203450	4
P5416203400	3	P5417137063	11	P5417607400	7	P5418605063	6
P5416203450	3	P5417137075	11	P5417607450	7	P5418605075	6
P5416605063	5	P5417137090	11	P5418111076	10	P5418605090	6
P5416605075	5	P5417137110	11	P5418111091	10	P5418605110	6

Index

Code	Page
P5418605125	6
P5418605140	6
P5418605160	6
P5418605180	6
P5418605200	6
P5418605225	6
P5418605250	6
P5418605280	6
P5418605315	6
P5418605355	6
P5418605400	6
P5418605450	6
P5418607063	7
P5418607075	7
P5418607090	7
P5418607110	7
P5418607125	7
P5418607140	7
P5418607180	7, 7
P5418607200	7
P5418607225	7
P5418607250	7
P5418607280	7
P5418607315	7
P5418607355	7
P5418607400	7
P5418607450	7

Terms and Conditions of Sale
Definition

Where the context permits:

Agreement means the agreement between the Vendor and the Customer for the supply of Goods by the Vendor to the Customer and shall be constituted by these Terms and if any, the Vendor's quotation, Credit Arrangement and Guarantee.

Contract means the contract for the sale and purchase of the Goods as provided in clause 3.

Credit Arrangement means the credit terms available to the Customer pursuant to an application by the Customer for the provision of Goods on credit submitted to the Vendor using the Vendor's standard credit application form and accepted in writing by the Vendor.

Customer means the person with whom the Vendor has agreed to supply Goods pursuant to the Agreement.

Goods means the goods and/or services agreed to be supplied by the Vendor and purchased by the Customer pursuant to the Agreement, more particularly described in Schedule 1 hereto.

Guarantee means the guarantee document provided by the Customer or the Customer's directors, shareholders or principals to the Vendor to guarantee the performance of the Agreement by the Customer.

Proprietary Information means any and all information and intellectual property relating to the Goods or the installation or operation of the Goods including but not limited to patents, designs, drawings, instruction booklets, specifications, circuit drawings, componentry, trade secrets, trade marks and copyright in such information and intellectual property.

Return of Goods Policy means the policy document setting out the procedures on return of any Goods to the Vendor, as updated by the Vendor from time to time, a current copy of which is annexed to these Terms as Schedule 2 hereto.

Terms means these general terms and conditions of sale and any further or other conditions of sale amending or adding to those conditions as agreed in writing by the Vendor.

Territory means Indonesia.

VAT means value added tax, goods and services tax or any other similar tax, if any, in the Territory.

Vendor means PT Georg Fischer Indonesia.

Quotations and Purchase Orders

1. Quotations from the Vendor are valid for a period of thirty (30) days from the date of issue or otherwise specified in the quotation. Prices given in any quotation by the Vendor are applicable to that quotation only and will not apply in any other instances. A quotation from the Vendor is not an offer to sell.
2. In order to purchase the Goods, the Customer must place with the Vendor a written purchase order setting out an order number, the Vendor's quotation number (if applicable), full description of the Goods to be purchased, the delivery date, delivery point and any other information required by the Vendor. The purchase order may be accepted or rejected by Vendor.
3. A Contract shall be formed by and upon the Vendor accepting in writing a purchase order from the Customer pursuant to clause 2 and each Contract shall be governed by the Agreement.
4. The Agreement shall take precedence over any other oral or written representations, agreements, arrangements or understandings relating to the Goods and any matters in connection therewith.
5. Any conditions or terms of purchase submitted by the Customer deviating from or inconsistent with the Agreement will not bind the Vendor notwithstanding any statement by the Customer in its purchase order that its terms and conditions prevail over the Agreement.
6. The Vendor may at its discretion, as a condition of acceptance of a purchase order require the Customer to provide to the Vendor cash deposit, Guarantee, bank guarantee or enter into a Credit Arrangement prior to delivery of the Goods.

Payment of purchase price

7. Purchase orders are accepted by the Vendor subject to the condition that the Customer shall pay promptly the purchase price set out in the Vendor's current price list for the Goods as of the date the order is accepted by the Vendor, or as otherwise quoted by the Vendor in writing.
8. Copies of the Vendor's current price list are available on request. All prices are subject to alteration without notice.
9. The purchase price, unless otherwise expressly stated, does not include any delivery charges, packaging, freight, assembly costs, installation costs, costs and charges of third party suppliers such as electricians, insurance or any statutory sales, excise, VAT, or other taxes, duties or imposts, all of which may be added to the purchase price or otherwise will be paid by the Customer or reimbursed by the Customer to the Vendor, as the Vendor may elect.

Syarat-syarat dan Ketentuan-ketentuan Penjualan
Definisi

Bila konteksnya mengizinkan:

Perjanjian berarti perjanjian antara Penjual dan Pelanggan untuk pasokan Barang oleh Penjual kepada Pelanggan dan terdiri dari Syarat-syarat ini dan jika ada, daftar harga Penjual, Pengaturan Kredit dan Jaminan.

Kontrak berarti kontrak untuk penjualan dan pembelian Barang seperti yang ditentukan di dalam klausul 3.

Pengaturan Kredit berarti syarat-syarat kredit yang tersedia bagi Pelanggan berdasarkan lamaran oleh Pelanggan untuk penyediaan Barang atas kredit yang diserahkan kepada Penjual dengan menggunakan formulir lamaran kredit standar Penjual dan diterima secara tertulis oleh Penjual.

Pelanggan berarti orang yang dengannya Penjual telah setuju untuk memasok Barang sesuai dengan Perjanjian.

Barang berarti barang dan/atau jasa yang disetujui untuk dipasok oleh Penjual dan dibeli oleh Pelanggan sesuai dengan Perjanjian, secara lebih khusus diuraikan di dalam Lampiran 1 pada Perjanjian ini.

Jaminan berarti dokumen jaminan yang diberikan oleh Pelanggan atau para direktur, pemegang saham atau prinsipal Pelanggan kepada Penjual untuk menjamin pelaksanaan Perjanjian oleh Pelanggan.

Informasi Hak Milik berarti setiap dan semua informasi dan hak milik intelektual yang terkait dengan Barang atau instalasi atau operasi Barang termasuk namun tidak terbatas pada paten, desain, gambar, buku instruksi, spesifikasi, gambar sirkuit, komponen, rahasia dagang, merek dagang dan hak cipta di dalam informasi dan hak milik intelektual seperti itu.

Kebijakan Pengembalian Barang berarti dokumen kebijakan yang mengemukakan prosedur-prosedur mengenai pengembalian Barang apa pun kepada Penjual, sebagaimana diperbarui oleh Penjual dari waktu ke waktu, yang salinannya sekarang ini dilampirkan pada Syarat-syarat ini sebagai Lampiran 2 pada Perjanjian ini.

Syarat-syarat berarti syarat-syarat dan ketentuan-ketentuan umum penjualan dan ketentuan-ketentuan penjualan lebih lanjut atau lain apa pun yang memperbaiki atau menambahkan ketentuan-ketentuan tersebut seperti yang disetujui secara tertulis oleh Penjual.

Wilayah berarti Indonesia.

VAT berarti pajak pertambahan nilai, pajak barang dan jasa atau pajak lainnya yang sejenis, apabila ada, dalam Wilayah.

Penjual berarti PT Georg Fischer Indonesia.

Daftar Harga dan Pesanan Pembelian

1. Daftar Harga dari Penjual berlaku selama tiga puluh (30) hari sejak tanggal pengeluaran atau kalau tidak ditentukan lain di dalam daftar harga. Harga-harga yang diberikan di dalam daftar harga apa pun oleh Penjual hanya berlaku bagi daftar harga tersebut dan tidak akan berlaku dalam hal-hal lain apa pun. Sebuah daftar harga dari Penjual bukan merupakan penawaran untuk menjual.
2. Guna membeli Barang, Pelanggan harus memberikan kepada Penjual sebuah pesanan pembelian tertulis yang mengemukakan sebuah nomor pesanan, nomor daftar harga Penjual (jika relevan), uraian lengkap mengenai Barang yang akan dibeli, tanggal penyerahan, tempat penyerahan dan informasi lain apa pun yang diperlukan oleh Penjual. Pesanan pembelian tersebut mungkin diterima atau ditolak oleh Penjual.
3. Sebuah Kontrak harus dibentuk dengan dan setelah Penjual menerima secara tertulis sebuah pesanan pembelian dari Pelanggan berdasarkan klausul 2 dan masing-masing Kontrak diatur oleh Perjanjian.
4. Perjanjian harus didahulukan daripada pernyataan, perjanjian, pengaturan atau pemahaman lisan atau tertulis lain apa pun yang terkait dengan Barang dan persoalan apa pun sehubungan dengannya.
5. Ketentuan-ketentuan atau syarat-syarat pembelian apa pun yang diserahkan oleh Pelanggan yang menyimpang dari atau tidak sesuai dengan Perjanjian tidak akan mengikat Penjual meskipun ada pernyataan apa pun oleh Pelanggan dalam pesanan pembelinya bahwa syarat-syarat dan ketentuan-ketentuannya harus didahulukan daripada Perjanjian.
6. Penjual boleh atas kebijakannya, sebagai sebuah ketentuan penerimaan suatu pesanan pembelian mewajibkan Pelanggan untuk memberikan kepada Penjual tanda jadi tunai, Jaminan, jaminan bank atau mengadakan suatu Pengaturan Kredit sebelum penyerahan Barang.

Pembayaran harga pembelian

7. Pesanan-pesanan pembelian diterima oleh Penjual dengan ketentuan bahwa Pelanggan harus segera membayar harga pembelian yang tercantum di dalam daftar harga terbaru Penjual sejak tanggal pesanan diterima oleh Penjual, atau seperti yang disebutkan lain oleh Penjual secara tertulis.
8. Salinan-salinan daftar harga terbaru Penjual tersedia jika diminta. Semua harga bisa mengalami perubahan tanpa pemberitahuan.
9. Harga pembelian, kecuali kalau dinyatakan lain secara tegas, tidak termasuk biaya penyerahan, pengemasan, angkutan, ongkos perakitan, ongkos instalasi, ongkos dan beban para pemasok pihak ketiga seperti tukang listrik, asuransi atau penjualan apa pun yang wajib berdasarkan undang-undang, cukai, pajak barang dan jasa (VAT), atau pajak-pajak, bea-bea atau beban lain apa pun, yang semuanya mungkin ditambahkan pada harga pembelian atau kalau tidak akan dibayar oleh Pelanggan atau

<p>10. Payment of the purchase price must be made in full in cash before delivery or within 30 days after the date of the invoice or otherwise in accordance with the Customer's Credit Arrangement (if any) as amended in writing by the Vendor from time to time.</p> <p>11. The Customer must not set off any money owing or alleged to be owing by the Vendor against money due by the Customer to the Vendor.</p> <p>12. The Customer acknowledges that the Vendor is a member of a group of companies which have as their ultimate parent Georg Fischer Ltd. The Customer agrees that the Vendor and/or any other Georg Fischer Ltd. company is entitled to exercise a right of set off to the extent the Customer is indebted to the Vendor or to any Georg Fischer Ltd. company against any money due by the Vendor or any Georg Fischer Ltd. company to the Customer on this or any other account</p> <p>13. If the Customer does not pay to the Vendor all money by the due date for payment, without prejudice to any other rights which it may have against the Customer, the Vendor may require the Customer to pay upon demand interest at 8 % per annum calculated from the due date on daily balances of amounts unpaid.</p> <p>14. If VAT is payable on a supply pursuant to the Agreement, the Customer must also pay to the Vendor an additional amount equal to the VAT payable. This clause does not apply to the extent that the purchase price is expressly stated to be VAT inclusive. The Customer must pay the VAT amount at the same time as the Customer must pay the purchase price.</p> <p>Cancellation of orders</p> <p>15. Purchase orders may not be altered or cancelled without the written consent of the Vendor. If the Vendor agrees to alter or cancel the purchase order, the Customer will indemnify the Vendor against any loss, damage and expense incurred by the Vendor in relation to the cancellation or alteration of that purchase order including the cost of return freight, return shipping to factory of origin, items purchased from third parties for inclusion in the Goods and all labour and engineering costs incurred by the Vendor in the execution or part execution of the Goods and including compensation payable to any supplier of the Vendor and loss of profit.</p> <p>Return of Goods and credits</p> <p>16. The Customer is deemed to have accepted the Goods unless it has made a claim in accordance with clause 17.</p> <p>17. The Customer may reject any non Customized Goods which are wrongly supplied or oversupplied by notifying the Vendor of the claim and providing full particulars of the claim in writing within two (2) business days of receipt of those Goods. The Vendor may dispute any such claim.</p> <p>18. Any Non Customized Goods returned by the Customer must comply with the Return of Goods Policy.</p> <p>19. The Customer must not return any Goods to the Vendor unless it has complied with clauses 17 and 18 and has done all things necessary to permit the Vendor to examine the Goods to the Vendor's satisfaction.</p> <p>Delivery and storage</p> <p>20. All quoted delivery or consignment dates are estimates only. The Vendor is not obliged to meet such dates and will not be liable to the Customer by reason of delays caused by any reason whatsoever.</p> <p>21. The Vendor is deemed to have delivered the Goods when the Goods are made available to the Customer for physical collection by or on behalf of the Customer at the Customer's nominated delivery point ("Delivery"). Any unloading or loading shall be the Customer's responsibility, unless otherwise agreed in writing by the Vendor.</p> <p>22. The Vendor may deliver the Goods by instalments (where in the Vendor's opinion this is reasonable to do so) and issue interim invoices to the Customer.</p> <p>23. Without limiting any other provisions in the Agreement, failure by the Customer to pay any instalment, or any other amount when due, will entitle the Vendor to withhold or delay delivery of any remaining Goods ordered.</p> <p>24. If the Customer is unable to collect the Goods at the Customer's nominated delivery point on the delivery day, the Vendor may (at its option and without limiting its other rights and remedies) arrange suitable storage of the Goods, whether at its premises or elsewhere and the Customer must pay or reimburse all costs and expenses of storage, insurance, demurrage, handling and other charges associated with such storage. Delivery shall be deemed to have occurred notwithstanding the Customer's inability to collect the Goods.</p>	<p>diganti oleh Pelanggan kepada Penjual, seperti yang mungkin dipilih oleh Penjual.</p> <p>10. Harga pembelian harus dibayar penuh secara tunai sebelum pengiriman atau dalam waktu 30 hari setelah tanggal faktur atau lainnya sesuai dengan Pengaturan Kredit Pelanggan (jika ada) seperti yang diamendemen secara tertulis oleh Penjual dari waktu ke waktu.</p> <p>11. Pelanggan tidak boleh menjumpakan hutang uang apa pun yang ditangkan atau diduga ditangkan oleh Penjual dari uang yang harus dibayar oleh Pelanggan kepada Penjual.</p> <p>12. Pelanggan mengakui bahwa Penjual adalah anggota dari sebuah kelompok perusahaan yang memiliki sebagai induk tertinggi mereka Georg Fischer Ltd. Pelanggan setuju bahwa Penjual dan/atau perusahaan Georg Fischer Ltd. lain mana pun berhak menggunakan hak pemotongan jika Pelanggan berutang kepada Penjual atau kepada perusahaan Georg Fischer Ltd. mana pun dari uang apa pun yang harus dibayar oleh Penjual atau perusahaan Georg Fischer Ltd. mana pun kepada Pelanggan pada rekening ini atau rekening lain mana pun</p> <p>13. Jika Pelanggan tidak membayar kepada Penjual semua uang hingga tanggal jatuh tempo untuk pembayaran, tanpa mengurangi hak-hak lain apa pun yang mungkin dimilikinya terhadap Pelanggan, Penjual boleh mewajibkan Pelanggan untuk membayar sewaktu diminta pembayaran bunga dengan suku bunga 8% per tahun yang dihitung dari tanggal jatuh tempo atas saldo harian jumlah yang belum dibayar.</p> <p>14. Jika VAT harus dibayar atas suatu pasokan berdasarkan Perjanjian, Pelanggan juga harus membayar kepada Penjual suatu jumlah tambahan yang sama dengan VAT yang harus dibayar. Klausul ini tidak berlaku jika harga pembelian dinyatakan secara tegas sebagai termasuk VAT. Pelanggan harus membayar jumlah VAT pada saat yang sama seperti Pelanggan harus membayar harga pembelian.</p> <p>Pembatalan Pesanan</p> <p>15. Pesanan pembelian tidak boleh diubah atau dibatalkan tanpa izin tertulis dari Penjual. Jika Penjual setuju mengubah atau membatalkan pesanan pembelian tersebut, Pelanggan akan mengganti rugi kepada Penjual kerugian, ganti kerugian dan biaya apa pun yang diadakan oleh Penjual terkait dengan pembatalan atau perubahan pesanan pembelian tersebut termasuk ongkos angkutan balik, pengiriman balik ke pabrik asal, item-item yang dibeli dari pihak-pihak ketiga untuk digabungkan ke dalam Barang dan semua ongkos tenaga kerja dan keteknikan yang diadakan oleh Penjual dalam eksekusi atau eksekusi sebagian Barang dan termasuk kompensasi yang harus dibayar kepada pemasok apa pun dari Penjual dan kehilangan laba.</p> <p>Pengembalian Barang dan Kredit</p> <p>16. Pelanggan dianggap telah menerima Barang kecuali kalau ia telah membuat klaim sesuai dengan klausul 17.</p> <p>17. Pelanggan boleh menolak Barang bukan khusus yang dipasok secara salah atau dipasok berlebih dengan memberitahukan klaim tersebut kepada Penjual dan memberikan rincian yang lengkap mengenai klaim tersebut secara tertulis dalam waktu dua (2) hari kerja setelah penerimaan Barang tersebut. Penjual boleh memperdebatkan klaim apa pun seperti itu.</p> <p>18. Barang bukan khusus apa pun yang dikembalikan oleh Pelanggan harus mematuhi Kebijakan Pengembalian Barang.</p> <p>19. Pelanggan tidak boleh mengembalikan Barang apa pun kepada Penjual kecuali kalau ia telah mematuhi klausul 17 dan 18 dan telah melakukan segala hal yang diperlukan untuk mengizinkan Penjual memeriksa Barang yang memuaskan Penjual.</p> <p>Penyerahan dan Penyimpanan</p> <p>20. Semua tanggal penyerahan atau pengiriman yang disebutkan hanyalah perkiraan. Penjual tidak wajib memenuhi tanggal-tanggal tersebut dan tidak akan bertanggung jawab kepada Pelanggan karena penundaan-penundaan yang disebabkan oleh alasan apa pun juga.</p> <p>21. Penjual dianggap telah menyerahkan Barang ketika Barang dibuat tersedia kepada Pelanggan untuk pengambilan secara fisik oleh atau atas nama Pelanggan di tempat penyerahan yang disebutkan Pelanggan ("Penyerahan"). Pembongkaran muatan atau pemuatan apa pun adalah tanggung jawab Pelanggan, kecuali kalau disetujui lain secara tertulis oleh Penjual.</p> <p>22. Penjual boleh menyerahkan Barang dengan cicilan/ bertahap (bila menurut pendapat Penjual ini layak untuk berbuat demikian) dan menerbitkan faktur-faktur sementara kepada Pelanggan.</p> <p>23. Tanpa membatasi ketentuan-ketentuan lain apa pun di dalam Perjanjian, kegagalan oleh Pelanggan untuk membayar cicilan apa pun, atau jumlah lain apa pun ketika jatuh tempo, akan membuat Penjual berhak menahan atau menunda penyerahan Barang apa pun selebihnya yang dipesan.</p> <p>24. Jika Pelanggan tidak dapat mengambil Barang di tempat penyerahan yang disebutkan Pelanggan pada hari penyerahan, Penjual boleh (atas pilihannya dan tanpa membatasi hak-hak dan tindakan-tindakan perbaikannya yang lain) mengatur penyimpanan Barang yang sesuai, apakah di tempatnya atau di tempat lain dan Pelanggan harus membayar atau mengganti semua ongkos dan biaya penyimpanan, asuransi, kegagalan dalam pemuatan dan pembongkaran muatan, penanganan dan beban-beban lain yang terkait dengan penyimpanan seperti itu. Penyerahan harus dianggap telah terjadi meskipun Pelanggan tidak mampu mengambil Barang.</p>
--	--

<p>Title and risk</p> <p>25. Title to the Goods shall remain with the Vendor until all monies owing to the Vendor by the Customer has been paid in full (whether such monies are payable under a specific contract or any other account whatsoever).</p> <p>26. Until such time that the Customer has paid in full all monies owing to the Vendor, the Customer shall (subject to its right to deal with the Goods in the ordinary course of the Customer's business):</p> <p>(a) keep the Goods stored separately and marked so that they are clearly and easily identifiable as the Vendor's property and inform the Vendor of the location of the Goods, if requested; and</p> <p>(b) indemnify the Vendor against any claim arising out of the possession, use or disposal of the Goods by the Customer or repossession or attempted repossession by the Vendor.</p> <p>27. If:</p> <p>(a) payment is not made in accordance with the invoice; or</p> <p>(b) the Customer commits any other breach of this Agreement; or</p> <p>(c) the Customer becomes bankrupt or has an administrator, a receiver or a receiver and manager appointed or goes into liquidation, whether voluntarily or otherwise, or is wound up or dissolved or declared insolvent,</p> <p>and in the case of paragraphs (a) and (b), such breach is not remedied within fourteen (14) days after receiving written notice from the Vendor requiring the Customer to do so, then the Vendor may at any time, without notice to the Customer and without prejudice to any other rights which it may have against the Customer:</p> <p>(d) terminate this Agreement and the Contract; and/or</p> <p>(e) suspend some or all its obligations under any Contract with the Customer; and/or</p> <p>(f) enter upon any premises owned or occupied by the Customer where the Vendor reasonably believes the Goods may be stored and repossess the Goods without being liable for any damages caused.</p> <p>28. If the Customer sells the Goods before payment in full to the Vendor, or uses the Goods in a manufacturing or construction process of its own or some third party, the Customer holds the proceeds from the sale for and on behalf of the Vendor in respect of those Goods, and must keep such proceeds in a separate account until the liability to the Vendor is discharged and must immediately pay that amount to the Vendor.</p> <p>29. The risk in the Goods passes to the Customer at the time of Delivery.</p> <p>Insurance</p> <p>30. The Customer must insure and keep the Goods insured against all risks for goods of that kind from the time the risk in the Goods passes to the Customer until the time the property in the Goods passes to the Customer. The Customer holds the proceeds of that insurance for and on behalf of the Vendor up to the amount it owes the Vendor in respect of those Goods, and must keep such proceeds in a separate account until the liability to the Vendor is discharged and must immediately pay that amount to the Vendor.</p> <p>Limitation of liability for Goods</p> <p>31. To the maximum extent permitted by law, the Vendor makes no warranties or representations to the Customer except to the extent set out in the Agreement.</p> <p>32. The Vendor warrants the relevant Goods to be free from defects in workmanship and materials under normal use and service for the period commencing from the Delivery as set out in Schedule 3 ("Warranty Period"). This warranty does not cover costs of recovery of the Goods from the site or damage, fault, failure or malfunction due to external causes including accident, abuse, misuse, mechanical or electrical overload, abrasion, corrosion, incorrect installation by the Customer or a third party, failure to perform required preventative maintenance or normal wear and tear.</p> <p>33. During the Warranty Period, to the extent permitted by law, the Customer's sole remedy with respect to breach of warranties set out in clause 32 will be repair or replacement by the Vendor (as the Vendor may elect) of any such defective Goods at the Vendor's expense. The replacement or repaired Goods shall be covered by the unexpired portion of the Warranty Period in respect of the original Goods or for a period of ninety (90) days, whichever is the greater.</p> <p>34. For equipment forming part of the Goods which is not manufactured by the Vendor, the original manufacturer's warranty will apply. The Vendor's</p>	<p>Hak Milik dan Risiko</p> <p>25. Hak milik terhadap Barang tetap pada Penjual sebelum semua uang yang diutangkan kepada Penjual oleh Pelanggan telah dibayar penuh (baik uang tersebut harus dibayar berdasarkan suatu kontrak tertentu maupun rekening lain apa pun juga).</p> <p>26. Sebelum Pelanggan telah membayar penuh semua uang yang diutangkan kepada Penjual, Pelanggan harus (dengan tidak mengesampingkan haknya untuk menangani Barang dalam rangka menjalankan bisnis Pelanggan secara biasanya):</p> <p>(a) membuat Barang disimpan secara terpisah dan ditandai sedemikian rupa sehingga mereka dapat diidentifikasi dengan jelas dan mudah sebagai milik Penjual dan memberitahukan kepada Penjual tentang lokasi Barang, jika diminta; dan</p> <p>(b) mengganti rugi kepada Penjual atas klaim apa pun yang timbul dari pemilihan, penggunaan atau pembuangan Barang oleh Pelanggan atau pemilihan kembali atau upaya pemilihan kembali oleh Penjual.</p> <p>27. Jika:</p> <p>(a) suatu pembayaran tidak dilakukan sesuai dengan faktur; atau</p> <p>(b) Pelanggan melakukan pelanggaran lain apa pun terhadap Perjanjian ini; atau</p> <p>(c) Pelanggan menjadi bangkrut atau telah menunjuk seorang administrator, seorang kurator atau seorang kurator dan manajer atau mengalami likuidasi, apakah dengan sengaja atau tidak, atau diakhiri atau dibubarkan atau dinyatakan tidak mampu membayar,</p> <p>dan dalam hal ayat (a) dan (b), pelanggaran seperti itu tidak diperbaiki dalam waktu empat belas (14) hari setelah menerima pemberitahuan tertulis dari Penjual yang mewajibkan Pelanggan berbuat demikian, maka Penjual boleh kapan pun, tanpa pemberitahuan kepada Pelanggan dan tanpa mengurangi hak-hak lain apa pun yang mungkin dimilikinya terhadap Pelanggan:</p> <p>(d) mengakhiri Perjanjian ini dan Kontrak; dan/atau</p> <p>(e) menunda sebagian atau semua kewajibannya berdasarkan Kontrak apa pun dengan Pelanggan; dan/atau</p> <p>(f) memasuki tempat-tempat apa pun yang dimiliki atau ditempati oleh Pelanggan di mana Penjual layak percaya Barang mungkin disimpan dan memiliki kembali Barang tanpa bertanggung jawab atas ganti kerugian apa pun yang disebabkan.</p> <p>28. Jika Pelanggan menjual Barang sebelum pembayaran penuh kepada Penjual, atau menggunakan Barang dalam proses pembuatan atau konstruksi miliknya sendiri atau pihak ketiga tertentu, Pelanggan memegang hasil dari penjualan untuk dan atas nama Penjual terkait dengan Barang tersebut, dan harus menyimpan hasil penjualan tersebut di dalam sebuah rekening tersendiri sampai kewajiban kepada Penjual dibebaskan dan harus segera membayar jumlah tersebut kepada Penjual.</p> <p>29. Risiko di dalam Barang pindah kepada Pelanggan pada saat Penyerahan.</p> <p>Asuransi</p> <p>30. Pelanggan harus mengasuransikan dan membuat Barang diasuransikan terhadap semua risiko untuk Barang jenis itu sejak risiko di dalam Barang berpindah kepada Pelanggan sampai hak milik dalam Barang berpindah kepada Pelanggan. Pelanggan memegang hasil asuransi tersebut tanpa bukti untuk dan atas nama Penjual sampai jumlah yang diutangkannya kepada Penjual terkait dengan Barang tersebut, dan harus menyimpan hasil penjualan tersebut di dalam sebuah rekening tersendiri sampai kewajiban kepada Penjual dibebaskan dan harus segera membayar jumlah tersebut kepada Penjual.</p> <p>Pembatasan Tanggung Jawab atas Barang</p> <p>31. Sejauh diperbolehkan oleh undang-undang, Penjual tidak membuat jaminan atau pernyataan apa pun kepada Pelanggan kecuali sejauh yang dikemukakan di dalam Perjanjian.</p> <p>32. Penjual menjamin Barang yang terkait bebas dari cacat dalam pembuatan dan bahan di bawah penggunaan dan pemakaian normal untuk periode mulai dari Penyerahan seperti yang dikemukakan di dalam Lampiran 3 ("Periode Jaminan"). Jaminan ini tidak mencakup ongkos-ongkos pemulihan Barang dari tempat kerusakan, kesalahan, kegagalan atau kegagalan fungsi karena sebab-sebab eksternal termasuk kecelakaan, penyalahgunaan, kesalahan pemakaian, beban mekanis atau listrik berlebih, abrasi, korosi, instalasi yang tidak benar oleh Pelanggan atau pihak ketiga, kegagalan melakukan pemeliharaan pencegahan yang diperlukan atau keausan normal.</p> <p>33. Selama Periode Jaminan, sejauh diperbolehkan oleh undang-undang, tindakan perbaikan Pelanggan satu-satunya yang terkait dengan pelanggaran jaminan-jaminan yang dikemukakan di dalam klausul 32 akan berupa perbaikan atau penggantian oleh Penjual (seperti yang boleh dipilih Penjual) Barang cacat apa pun seperti itu dengan biaya Penjual. Barang pengganti atau Barang yang diperbaiki tercakup oleh bagian Periode Jaminan yang belum berakhir untuk Barang semula atau selama sembilan puluh (90) hari, mana saja yang lebih besar.</p> <p>34. Untuk peralatan yang merupakan bagian dari Barang yang tidak dibuat oleh Penjual, jaminan pembuat yang asli akan berlaku. Tanggung jawab</p>
--	---

<p>liability for such equipment shall not exceed the liability of the original manufacturer.</p> <p>35. The liability of the Vendor under the Agreement will be reduced by the amount of any contributory loss and/or damage to the extent caused by the act and/or omission of the Customer.</p> <p>36. To the maximum extent permitted by law and notwithstanding any provision to the contrary in this Agreement, the Vendor's total liability under each Contract (whether that liability arises under contract, tort, equity, statute or otherwise) for any loss, damage or expense arising out of or in connection with its performance of the Contract, shall be limited to the purchase price paid by the Customer to the Vendor for the Goods covered by that Contract and in no event shall the Vendor be liable for loss (whether direct or indirect) of profits, opportunity, revenue, goodwill, use, production, contracts, business or anticipated savings, corruption or destruction of data or for any special or consequential loss or damage whatsoever.</p>	<p>Penjual untuk peralatan seperti itu tidak boleh melebihi tanggung jawab pembuat yang asli.</p> <p>35. Tanggung jawab Penjual berdasarkan Perjanjian akan dikurangi dengan jumlah kerugian dan/atau ganti kerugian apa pun jika disebabkan oleh tindakan dan/atau kelalaian Pelanggan.</p> <p>38. Sejauh diperbolehkan oleh undang-undang dan terlepas dari ketentuan apa pun yang bertentangan di dalam Perjanjian ini, seluruh tanggung jawab Penjual berdasarkan masing-masing Kontrak (apakah tanggung jawab tersebut timbul berdasarkan kontrak, kesalahan, keadilan, undang-undang atau lainnya) untuk kerugian, ganti kerugian atau biaya apa pun yang timbul karena atau sehubungan dengan pelaksanaan Kontraknya, terbatas pada harga pembelian yang dibayar oleh Pelanggan kepada Penjual untuk Barang yang tercakup oleh Kontrak tersebut dan Penjual sama sekali tidak bertanggung jawab atas kerugian (baik langsung maupun tidak langsung) laba, peluang, penghasilan, nama baik, penggunaan, produksi, kontrak, bisnis atau penghematan yang diharapkan, kerusakan atau kehancuran data atau atas kerugian atau ganti kerugian khusus atau akibat apa pun juga.</p>
<p>Proprietary Information</p> <p>37. The Customer acknowledges that all Proprietary Information and all right title and interest therein are the sole property of or licensed by the Vendor and the Customer shall gain no rights, title or interest in the Proprietary Information whatsoever. The Customer specifically acknowledges the Vendor's exclusive rights to ownership of any modification, translation or adaptation of the Proprietary Information and any other improvement or development based thereon whether developed, supplied, installed or paid for by or on behalf of the Customer or any buyer of the Customer or otherwise.</p> <p>38. The Customer must not and must not permit any person reasonably within the Customer's control to:</p> <ul style="list-style-type: none"> - modify any of the Goods; and/or - copy, clone, reverse engineer any hardware Goods; and/or - copy, decompile, disassemble or reverse engineer any software Goods; and/or - copy, modify or decompile any documents accompanying the Goods, <p>without the Vendor's prior written consent, and in the event the Customer breaches its obligations under this clause, the Vendor may immediately terminate this Agreement and the Contract and the Customer shall indemnify and hold harmless the Vendor against any and all losses or damages related to such breach of the Agreement.</p>	<p>Informasi Hak Milik</p> <p>37. Pelanggan mengakui bahwa semua Informasi Hak Milik dan semua hak milik dan kepentingan di dalamnya adalah milik tunggal atau dilisensikan oleh Penjual dan Pelanggan tidak memperoleh hak, hak milik atau kepentingan apa pun juga di dalam Informasi Hak Milik. Pelanggan secara khusus mengakui hak-hak tunggal atas kepemilikan modifikasi, penerjemahan atau adaptasi apa pun atas Informasi Hak Milik dan perbaikan atau pengembangan lain apa pun atas dasar hal itu baik dikembangkan, dipasok, dipasang maupun dibayar oleh atau atas nama Pelanggan atau pembeli mana pun dari Pelanggan atau lainnya.</p> <p>38. Pelanggan tidak boleh dan selayaknya tidak boleh mengizinkan siapapun yang ada dalam kendali Pelanggan untuk:</p> <ul style="list-style-type: none"> - memodifikasi apa pun dari Barang; dan/atau - menyalin, menduplikasi, merekayasa balik Barang perangkat keras apa pun; dan/atau - menyalin, mendekompilasikan, membongkar atau merekayasa balik Barang perangkat lunak apa pun; dan/atau - menyalin, memodifikasi atau mendekompilasikan dokumen-dokumen apa pun yang menyertai Barang, <p>tanpa izin tertulis dari Penjual sebelumnya, dan jika Pelanggan melanggar kewajiban-kewajibannya berdasarkan klausul ini, Penjual boleh segera mengakhiri Perjanjian ini dan Kontrak dan Pelanggan harus mengganti rugi dan melindungi Penjual dari setiap dan semua kerugian atau ganti kerugian yang terkait dengan pelanggaran terhadap Perjanjian seperti itu.</p>
<p>Re-export</p> <p>39. The Goods supplied are intended for use only in Indonesian Territory. If any Goods are re-exported by the Customer, it is the Customer's responsibility to ensure that such Goods and the use to which they are put will comply with all applicable laws of that country.</p>	<p>Ekspor Kembali</p> <p>39. Barang yang dipasok dimaksudkan hanya untuk digunakan di Wilayah Indonesia. Jika Barang apa pun diekspor kembali oleh Pelanggan, adalah tanggung jawab Pelanggan untuk memastikan bahwa Barang seperti itu dan ke mana mereka digunakan akan mematuhi semua undang-undang yang berlaku di negara tersebut.</p>
<p>Restriction on Use</p> <p>40. The Customer acknowledges that the Goods purchased by the Customer may not be sold, leased or otherwise transferred to or utilised by, an end-user engaged in activities related to weapons of mass destruction including but not limited to activities related to design, development, production or use of nuclear materials, nuclear facilities or nuclear weapons, missiles or support of missiles projects or chemical or biological weapons.</p>	<p>Larangan mengenai Penggunaan</p> <p>40. Pelanggan mengakui bahwa Barang yang dibeli oleh Pelanggan tidak boleh dijual, disewakan atau dialihkan kepada atau digunakan oleh, pemakai akhir yang melakukan kegiatan-kegiatan yang terkait dengan senjata-senjata penghancuran massal termasuk namun tidak terbatas pada kegiatan-kegiatan yang terkait dengan desain, pengembangan, produksi atau penggunaan bahan-bahan nuklir, fasilitas-fasilitas nuklir atau senjata-senjata nuklir, peluru-peluru kendali atau dukungan proyek-proyek peluru kendali atau senjata-senjata kimia atau biologis.</p>
<p>Compliance</p> <p>41. In advertising, marketing, promoting, sales and installation of the Goods and in carrying on the Customer's business, each of the Customer, its owners, officers, directors, commissioners, employees or agents (collectively and individually in this clause, Customer) must comply with its, his or her obligations under any applicable law including without limitation, the Customer must:</p> <p>41.1 not make any untrue or misleading statement relating to the Vendor, its goods and services including the Goods, its business or its practices;</p> <p>41.2 comply with all applicable export and import laws and regulations, including associated embargo and sanction regulations and unless authorized by applicable governmental license or regulation, not directly or indirectly export or re-export any technical information or software subject to this Agreement (including direct products of such technical information or software) to any prohibited destination or country (including release to nationals, wherever they may be located, of any prohibited country) as specified in such applicable export regulations;</p> <p>41.3 not violate any health, safety or environmental protection law, regulation, order or safety standard affecting the conduct of its business or practices.</p> <p>42. Third Party Compliance</p>	<p>Kepatuhan</p> <p>41. Dalam periklanan, pemasaran, promosi, penjualan dan instalasi Barang dan dalam menjalankan bisnis Pelanggan, masing-masing Pelanggan, para pemilik, kantor, direktur, komisaris, karyawan atau agennya (secara bersama-sama atau sendiri-sendiri di dalam klausul ini, Pelanggan) harus mematuhi kewajiban-kewajibannya berdasarkan undang-undang apa pun yang berlaku termasuk, namun tidak terbatas pada, Pelanggan:</p> <p>41.1 tidak boleh membuat pernyataan apa pun yang tidak benar atau menyesatkan mengenai Penjual, barang-barang dan jasa-jasanya termasuk Barang, bisnisnya atau praktik-praktiknya;</p> <p>41.2 harus mematuhi semua undang-undang dan peraturan-peraturan ekspor dan impor yang berlaku, termasuk peraturan-peraturan embargo dan sanksi yang terkait dan kecuali kalau diberi wewenang oleh lisensi atau peraturan pemerintah yang berlaku, tidak boleh secara langsung maupun tidak langsung mengekspor atau mengekspor kembali informasi teknis atau perangkat lunak apa pun yang tunduk pada Perjanjian ini (termasuk produk-produk langsung informasi teknis atau perangkat lunak seperti itu) ke tujuan atau negara terlarang mana pun (termasuk rilis ke warga negara, di mana pun mereka mungkin berlokasi, dari negara terlarang mana pun) seperti yang ditentukan di dalam peraturan-peraturan ekspor seperti itu yang berlaku;</p> <p>41.3 tidak boleh melanggar undang-undang, peraturan, perintah atau standar keamanan perlindungan lingkungan yang mempengaruhi perilaku bisnis atau praktik-praktik bisnisnya.</p> <p>42. Kepatuhan Pihak Ketiga</p>

<p>42.1 No Improper Means of Obtaining Business. Vendor and the Customer intend that no payments or transfers of value shall be made which have the purpose or effect of public or commercial bribery, acceptance of or acquiescence in extortion or kickbacks, or other unlawful or improper means of obtaining business.</p>	<p>42.1 Tanpa Cara yang Tidak Layak untuk Memperoleh Bisnis. Penjual dan Pelanggan berkehendak bahwa tidak ada pembayaran atau transfer nilai yang boleh dilakukan yang memiliki tujuan atau akibat penyuaian publik atau komersial, penerimaan atau persetujuan secara diam-diam atas pemerasan atau hadiah di bawah meja, atau cara-cara lain yang melanggar hukum atau tidak layak untuk memperoleh bisnis.</p>
<p>42.2 No Bribes. Customer will not, directly or indirectly, pay, offer, authorize or promise any monies or anything of value (such as gift, contributions, travel, or entertainment) to any person or organization (including any employee or official of any governmental authority, government owned or controlled entity, public international organization or political party; any candidate for political office; or any employee of any of the Customer's or Vendor's customers) for the purpose of improperly influencing their acts or decisions in violation of any anti-bribery or anti-corruption laws, including the United States Foreign Corrupt Practices Act, laws under the OECD Anti-Bribery Convention and local anti-corruption law (collectively, "Anti-Corruption Laws"). Customer will take appropriate actions to ensure that any person representing or acting under its instruction or control ("Customer's Agents") will also comply with this Clause 42.</p>	<p>42.2 Tanpa Penyuaian. Pelanggan tidak akan, secara langsung atau tidak langsung, membayar, menawarkan, menyetujui atau menjanjikan uang apa pun atau apa pun yang berharga (seperti hadiah, sumbangan, perjalanan, atau hiburan) kepada siapapun atau organisasi apa pun (termasuk karyawan atau pejabat apa pun dari otoritas pemerintah apa pun, badan yang dimiliki atau dikendalikan pemerintah, organisasi publik internasional atau partai politik; calon apa pun untuk kantor politik; atau karyawan apa pun dari para pelanggan Pelanggan atau Penjual yang mana pun) untuk tujuan mempengaruhi secara tidak layak tindakan atau keputusan mereka yang melanggar undang-undang anti-penyuaian atau anti-korupsi apa pun, termasuk Undang-Undang Praktik Korupsi Luar Negeri Amerika Serikat, undang-undang berdasarkan Konvensi Anti-Penyuaian OECD dan undang-undang anti-korupsi setempat (secara bersama-sama, "Undang-Undang Anti-Korupsi"). Pelanggan akan mengambil tindakan-tindakan yang semestinya guna memastikan bahwa siapapun yang mewakili atau bertindak berdasarkan instruksi atau kendalinya ("Agen-agen Pelanggan") juga akan mematuhi Klausul 42 ini.</p>
<p>42.3 No Kickbacks. No part of the payment of any amounts payable under this Agreement will be distributed to Vendor, its affiliates or customers, or any of its employees or their family members.</p>	<p>42.3 Tanpa Hadiah di Bawah Meja. Tidak ada bagian dari pembayaran jumlah apa pun yang harus dibayar berdasarkan Perjanjian ini akan dibagikan kepada Penjual, para afiliasi atau pelanggannya, atau karyawannya yang mana pun atau anggota keluarga mereka.</p>
<p>42.4 No Conflicts. Except as disclosed in writing to Vendor (in a questionnaire response or otherwise), Customer represents that it does not have any reason to believe that there are any potential conflicts of interest regarding its relationship with Vendor, such as family members who could potentially benefit from the commercial relationship established by this Agreement; and neither Customer, nor any of the Customer's Agents, have any family members who are government officials or political party candidates in a position to influence the Customer's commercial relationship with Vendor.</p>	<p>42.4 Tanpa Konflik. Kecuali seperti yang diungkapkan secara tertulis kepada Penjual (dalam jawaban kuesioner atau lainnya), Pelanggan menyatakan bahwa ia tidak memiliki alasan apa pun untuk percaya bahwa ada potensi konflik kepentingan apa pun mengenai hubungannya dengan Penjual, seperti anggota keluarga yang berpotensi bisa mendapatkan manfaat dari hubungan dagang yang diadakan oleh Perjanjian ini; dan baik Pelanggan maupun Agen Pelanggan yang mana pun tidak memiliki anggota keluarga apa pun yang merupakan pejabat pemerintah atau calon partai politik dalam posisi yang mempengaruhi hubungan dagang Pelanggan dengan Penjual.</p>
<p>42.5 Accurate Books and Records. Customer will maintain complete and accurate books and records in accordance with generally accepted accounting principles in Customer's jurisdiction, consistently applied, properly and accurately recording all payments made by the Customer or Customer's Agents in performance of this Agreement or related to it, and any commission, compensation, reimbursement, or other payment made by or on behalf of Vendor to the Customer or Customer's Agents. Customer will maintain a system of internal accounting controls reasonably designed to ensure that it maintains no off-the-book accounts and that its assets are used only in accordance with its management directives.</p>	<p>42.5 Buku dan Catatan yang Akurat. Pelanggan akan memegang buku-buku dan catatan-catatan yang lengkap dan akurat sesuai dengan prinsip-prinsip akuntansi yang berlaku umum di yurisdiksi Pelanggan, yang diterapkan secara konsisten, yang secara benar dan akurat mencatat semua pembayaran yang dilakukan oleh Pelanggan atau Agen Pelanggan dalam pelaksanaan Perjanjian ini atau yang terkait dengannya, dan komisi, kompensasi, penggantian, atau pembayaran lain apa pun yang dilakukan oleh atau atas nama Penjual kepada Pelanggan atau Agen Pelanggan. Pelanggan akan mempertahankan suatu sistem kontrol akuntansi internal yang dirancang secara layak untuk memastikan bahwa ia tidak menggunakan akun-akun di luar buku dan bahwa aset-asetnya hanya digunakan sesuai dengan arahan-arahan manajemennya.</p>
<p>42.6 Notification. Customer will notify Vendor promptly if (a) Customer or any of the Customer's Agents have reason to believe that a breach of this Clause 42 has occurred or is likely to occur; or (b) if any conflicts of interest arise after the signing of this Agreement, including if any of the Customer's Agents or their family members become a government official or political party candidate in a position to influence Customer's commercial relationship with Vendor. Customer will send all such notices to nominated e-mail address or to such other location as Vendor may designate in writing.</p>	<p>42.6 Pemberitahuan. Pelanggan akan memberitahukan kepada Penjual dengan segera jika (a) Pelanggan atau Agen Pelanggan yang mana pun memiliki alasan untuk percaya bahwa pelanggaran terhadap Klausul 42 ini telah terjadi atau mungkin terjadi; atau (b) jika konflik kepentingan apa pun timbul setelah penandatanganan Perjanjian ini, termasuk jika Agen Pelanggan yang mana pun atau anggota keluarga mereka menjadi pejabat pemerintah atau calon partai politik dalam posisi yang mempengaruhi hubungan dagang Pelanggan dengan Penjual. Pelanggan akan mengirimkan semua pemberitahuan seperti itu kepada alamat surat elektronik yang ditunjuk atau ke lokasi lain seperti itu yang mungkin diberitahukan Penjual secara tertulis.</p>
<p>42.7 Compliance Certification. Customer will, when and as may be requested by Vendor from time to time, provide to Vendor a written certification in form and substance satisfactory to Vendor that Customer is in compliance with this Clause 42.</p>	<p>42.7 Sertifikasi Kepatuhan. Pelanggan akan, bila dan seperti yang mungkin diminta oleh Penjual dari waktu ke waktu, memberikan kepada Penjual suatu sertifikasi tertulis dalam bentuk dan isi yang memuaskan bagi Penjual bahwa Pelanggan mematuhi Klausul 42 ini.</p>
<p>42.8 No Payments for Improper Activities. Vendor will not be required under any circumstances to take any action or make any payments that Vendor believes, in good faith, would cause it or its affiliated companies to be in violation of any Anti-Corruption Laws. If Vendor at any time believes, in good faith, that a breach of any of the representations and warranties in this Clause 42 has occurred or may occur, Vendor may withhold any commission, compensation, reimbursement, or other payment until such time as Vendor has received confirmation to its reasonable satisfaction</p>	<p>42.8 Tanpa Pembayaran untuk Kegiatan yang Tidak Layak. Penjual tidak akan diwajibkan dalam keadaan apa pun untuk mengambil tindakan apa pun atau melakukan pembayaran apa pun yang Penjual percayai, dengan niat baik, akan menyebabkannya atau perusahaan-perusahaan afiliasinya melanggar Undang-Undang Anti-Korupsi apa pun. Jika Penjual kapan pun percaya, dengan niat baik, bahwa suatu pelanggaran terhadap pernyataan dan jaminan di dalam Klausul 42 ini telah terjadi atau mungkin terjadi, Penjual boleh</p>

<p>that no breach has occurred or will occur. Vendor shall not be liable to Customer for any claim, losses, or damages whatsoever related to Vendor's decision to withhold any commission, compensation, reimbursement, or other payment under this provision.</p>	<p>menahan komisi, kompensasi, penggantian, atau pembayaran lain apa pun sampai setelah Penjual menerima konfirmasi yang memuaskannya secara layak bahwa tidak ada pelanggaran yang terjadi atau akan terjadi. Penjual tidak bertanggung jawab kepada Pelanggan atas klaim, kerugian, atau ganti kerugian apa pun juga yang terkait dengan keputusan Penjual untuk menahan komisi, kompensasi, penggantian, atau pembayaran lain apa pun juga berdasarkan ketentuan ini.</p>
<p>42.9 Audit Rights. If Vendor at any time believes, in good faith, that Customer has breached the warranties, representations or agreements in this Clause 42, then Vendor will have the right to audit Customer's books and records related to this Agreement in order to verify Customer's compliance with the provisions of this Clause 42. The audit will be performed by individuals selected by Vendor. However, upon request by Customer, Vendor will select in its sole discretion an independent third party to conduct an audit in order to certify to Vendor that no breach has occurred or will occur. Customer will fully cooperate in any audit conducted by or on behalf of Vendor.</p>	<p>42.9 Hak-hak Audit. Jika Penjual kapan pun percaya, dengan niat baik, bahwa Pelanggan telah melanggar jaminan-jaminan, pernyataan-pernyataan atau pengaturan-pengaturan di dalam Klausul 42 ini, maka Penjual akan berhak mengaudit buku-buku dan catatan-catatan Pelanggan yang terkait dengan Perjanjian ini guna memverifikasi kepatuhan Pelanggan terhadap ketentuan-ketentuan Klausul 42 ini. Audit tersebut akan dilakukan oleh orang-orang yang dipilih oleh Penjual. Akan tetapi, jika diminta oleh Pelanggan, Penjual akan memilih dengan kebijakannya sendiri pihak ketiga independen untuk melakukan audit guna menyatakan kepada Penjual bahwa tidak ada pelanggaran yang telah terjadi atau akan terjadi. Pelanggan akan bekerja sama sepenuhnya dalam audit apa pun yang dilakukan oleh atau atas nama Penjual.</p>
<p>42.10 Termination Rights. Any breach of the warranties, representations or agreements in Clauses 41 or 42 will constitute grounds for immediate termination of this Agreement for cause by Vendor and no commission, compensation, reimbursement or other payment will be due to Customer. Customer will indemnify and hold Vendor harmless against any actions, legal claims, demands, proceedings, losses, damages, costs, expenses and other liabilities of whatever nature resulting from Customer's breach of the representations, warranties and agreements contained in Clauses 41 or 42.</p>	<p>42.10 Hak-hak Pengakhiran. Pelanggaran apa pun terhadap jaminan-jaminan, pernyataan-pernyataan atau perjanjian-perjanjian apa pun di dalam Klausul 41 atau 42 akan menjadi dasar bagi pengakhiran segera Perjanjian ini dengan alasan yang tepat oleh Penjual dan tidak ada komisi, kompensasi, penggantian atau pembayaran lain akan harus dibayar kepada Pelanggan. Pelanggan akan mengganti rugi dan melindungi Penjual dari kerugian terhadap tindakan, tuntutan hukum, tuntutan, proses hukum, kerugian, ganti kerugian, ongkos, biaya dan tanggung jawab lain apa pun dari jenis apa pun juga yang diakibatkan oleh pelanggaran Pelanggan terhadap pernyataan-pernyataan, jaminan-jaminan dan perjanjian-perjanjian yang termuat di dalam Klausul 41 atau 42.</p>
<p>42.11 Data Privacy. Customer consents to the collection, processing and international transfer of data and information related to the business relationship between it and Vendor, including the transfer of personally identifiable data to and between Vendor and its affiliates wherever they may be located, for the purposes of allowing Vendor and its affiliates to evaluate its experience and qualifications and implement any business relationship that may now or subsequently exist between it and Vendor. Customer shall have the right to: (a) request reasonable access to this data; (b) rectify or cancel any inaccurate or expired data; and (c) object to any processing that is not in conformity with the purposes described herein. In this regard, Customer may exercise its rights by writing to Vendor at nominated e-mail address or to such other location as Vendor may designate in writing.</p>	<p>42.11 Privasi Data. Pelanggan menyetujui pengumpulan, pengolahan dan pemindahan data dan informasi internasional yang terkait dengan hubungan bisnis antara Pelanggan dan Penjual, termasuk pemindahan data yang dapat diidentifikasi secara pribadi kepada dan antara Penjual dan para afliasinya di mana pun mereka mungkin berada, untuk tujuan memungkinkan Penjual dan para afliasinya untuk mengevaluasi pengalaman dan kualifikasinya dan melaksanakan hubungan bisnis apa pun yang mungkin sekarang atau sesudahnya ada antara Pelanggan dan Penjual. Pelanggan berhak untuk: (a) meminta akses yang layak pada data ini; (b) memperbaiki atau membatalkan data apa pun yang tidak akurat atau sudah kedaluwarsa; dan (c) berkeberatan terhadap pemrosesan apa pun yang tidak sesuai dengan tujuan-tujuan yang diuraikan di dalam Perjanjian ini. Dalam hal ini, Pelanggan boleh menggunakan haknya dengan menulis kepada Penjual di alamat e-mail yang ditentukan atau ke lokasi lain seperti yang mungkin diberitahukan oleh Penjual secara tertulis.</p>
<p>42.12 This Clause 42 will not be affected by expiration or termination of this Agreement for any reason.</p>	<p>42.12 Klausul 42 ini tidak akan terpengaruhi oleh berakhirnya atau pengakhiran Perjanjian ini karena alasan apa pun.</p>
<p>43. The Customer must at its sole cost apply for and maintain during the term of the Agreement all necessary licences, permits and other consents or approval required by any relevant authority in the Territory relevant to the sale and installation of the Goods and if the Goods are installed by the Customer, they shall be installed in strict compliance with any applicable or appropriate standard and/or regulation in the Territory.</p>	<p>43. Pelanggan harus dengan biayanya sendiri melamar dan mempertahankan selama masa Perjanjian semua lisensi, izin dan perkenan atau persetujuan-persetujuan lainnya yang diperlukan dan diwajibkan oleh otoritas terkait apa pun di Wilayah sehubungan dengan penjualan dan instalasi Barang dan jika Barang dipasang oleh Pelanggan, mereka harus dipasang dengan mematuhi secara ketat standar dan/atau peraturan apa pun yang berlaku atau layak di Wilayah.</p>
<p>Termination</p>	<p>Pengakhiran</p>
<p>44. Either party may terminate this Agreement and the Contract by giving notice to the other party of its intention to terminate in any of the following circumstances:</p>	<p>44. Salah satu pihak boleh mengakhiri Perjanjian ini dan Kontrak dengan menyampaikan pemberitahuan kepada pihak lainnya mengenai maksudnya untuk mengakhiri dalam keadaan-keadaan apa pun berikut ini:</p>
<p>44.1 the other Party commits any breach of the provisions of this Agreement and has not remedied that breach within fourteen (14) days after receiving written notice from the party requiring it to do so;</p>	<p>44.1 Pihak lainnya melakukan pelanggaran apa pun terhadap ketentuan-ketentuan Perjanjian ini dan tidak memperbaiki pelanggaran tersebut dalam waktu empat belas (14) hari setelah menerima pemberitahuan tertulis dari pihak mewajibkannya berbuat demikian;</p>
<p>44.2 the other party has an administrator, a receiver or a receiver and manager appointed or goes into liquidation, whether voluntarily or otherwise, or is wound up or dissolved or declared insolvent; or</p>	<p>44.2 Pihak lainnya telah menunjuk seorang administrator, seorang kurator atau seorang kurator dan manajer atau mengalami likuidasi, baik dengan sengaja atau tidak, atau diakhiri atau dibubarkan atau dinyatakan tidak mampu membayar; atau</p>
<p>44.3 either party ceases to carry on business or any licence or authorisation it requires to carry on business is suspended or revoked.</p>	<p>44.3 Salah satu pihak berhenti menjalankan bisnis atau lisensi atau otorisasi apa pun yang diperlukannya untuk menjalankan bisnis diskors atau dicabut.</p>
<p>45. The Vendor may terminate this Agreement and the Contract at any time without cause on giving one (1) month's notice in writing to the Customer. In respect of any termination of this Agreement, the parties hereby waive the provisions of Article 1266 of the Indonesian Civil Code to the extent that no judicial approval shall be required in order to terminate this Agreement.</p>	<p>45. Penjual boleh mengakhiri Perjanjian ini dan Kontrak kapan pun tanpa sebab dengan menyampaikan pemberitahuan secara tertulis kepada Pelanggan satu (1) bulan sebelumnya. Dalam hal adanya pengakhiran Perjanjian ini, para pihak dengan ini mengesampingkan ketentuan Pasal 1266 Kitab Undang-Undang Hukum Perdata sejauh tidak ada persetujuan pengadilan yang diperlukan untuk mengakhiri Perjanjian ini.</p>

Miscellaneous	Lain-lain
<p>46. The fact that the Vendor fails to do, or delays in doing, something it is entitled to do under the Agreement, does not amount to a waiver of its right to do it. Any waiver must be agreed in writing by the Vendor.</p>	<p>46. Kenyataan bahwa Penjual gagal melakukan, atau terlambat dalam melakukan, sesuatu yang berhak dilakukannya berdasarkan Perjanjian, tidak berarti pelepasan haknya untuk melakukannya. Pelepasan hak apa pun harus disetujui secara tertulis oleh Penjual.</p>
<p>47. If a clause or part of a clause can be read in a way that makes it illegal, unenforceable or invalid, but can also be read in a way that makes it legal, enforceable and valid, it must be read in the latter way. If any clause or part of a clause is illegal, unenforceable or invalid, that clause or part is to be treated as removed from these Terms, but the rest of the Agreement is not affected.</p>	<p>47. Jika suatu klausul atau bagian dari suatu klausul bisa dibaca dengan cara yang membuatnya ilegal, tidak dapat diberlakukan atau tidak sah, namun bisa juga dibaca dengan cara yang membuatnya legal, dapat diberlakukan dan sah, itu harus dibaca dengan cara yang disebut belakangan itu. Jika suatu klausul atau bagian dari suatu klausul ilegal, tidak dapat diberlakukan atau tidak sah, klausul atau bagian tersebut harus diperlakukan sebagai dihilangkan dari Syarat-syarat ini, namun Perjanjian ini selebihnya tidak terpengaruh.</p>
<p>48. The Vendor shall not be liable for any failure to fulfil or any delay in fulfilling any obligation arising from the Agreement if the failure or delay has been caused directly or indirectly by any act of God, war or other civil commotion, terrorism, strikes, lockouts, stoppages and restraints of labour, breakdown of machinery, inability to obtain raw materials or fuel, fire or explosion, any government action or any other cause beyond the reasonable control of the Vendor and not a consequence of the Vendor's negligence.</p>	<p>48. Penjual tidak bertanggung jawab atas kegagalan apa pun untuk memenuhi atau keterlambatan apa pun dalam memenuhi kewajiban apa pun yang timbul dari Perjanjian jika kegagalan atau keterlambatan tersebut telah disebabkan secara langsung atau tidak langsung oleh keadaan kahar apa pun, perang atau huru-hara sipil lainnya, terorisme, pemogokan, penutupan, penghentian dan halangan tenaga kerja, kerusakan mesin-mesin, ketidakmampuan memperoleh bahan baku atau bahan bakar, kebakaran atau ledakan, tindakan pemerintah apa pun atau sebab lain apa pun di luar kendali layak Penjual dan bukan merupakan akibat dari kelalaian Penjual.</p>
<p>49. Any notice to be given to a party under the Agreement must be in writing and must be sent by post, facsimile or email to the address of that party shown in the quotation, purchase order or order acknowledgment. Notice is deemed to have been given at the time it would have been received in the normal course of post if sent by post, or if otherwise given at the time it was actually received.</p>	<p>49. Pemberitahuan apa pun yang disampaikan kepada suatu pihak berdasarkan Perjanjian harus secara tertulis dan harus dikirimkan melalui pos, faksimili atau e-mail ke alamat pihak tersebut yang ditunjukkan di dalam daftar harga, pesanan pembelian atau pengakuan pesanan. Pemberitahuan dianggap telah disampaikan pada waktu yang semestinya sudah diterima dalam masa pengiriman pos yang normal jika dikirimkan dengan pos, atau jika diberikan dengan cara lain pada saat pemberitahuan tersebut benar-benar diterima.</p>
<p>50. The Agreement is governed by and must be interpreted in accordance with the laws of the Territory. The Customer unconditionally submits to the non-exclusive jurisdiction of the courts of the Territory. The Agreement is not governed by the United Nations Convention on documents for the International Sale of Goods.</p>	<p>50. Perjanjian diatur oleh dan harus ditafsirkan sesuai dengan undang-undang Wilayah. Pelanggan secara tanpa syarat tunduk pada yurisdiksi non-tunggal pengadilan-pengadilan Wilayah. Perjanjian tidak diatur oleh Konvensi Perserikatan Bangsa-Bangsa mengenai dokumen-dokumen untuk Penjualan Barang Internasional.</p>
<p>51. This Agreement is entered into in the English and Indonesian languages and if there is any diversion between the English and Indonesian versions, then to the extent permitted by law, the English version shall prevail.</p>	<p>51. Perjanjian ini ditandatangani dalam bahasa Inggris dan Indonesia dan apabila ada perbedaan apa pun antara versi bahasa Inggris dan bahasa Indonesia, maka sejauh diperbolehkan berdasarkan hukum, versi bahasa Inggrisnya akan berlaku.</p>
<p>52. Where there is more than one Customer, then the liability of each shall be joint and several.</p>	<p>52. Bila ada lebih dari satu Pelanggan, maka tanggung jawab masing-masing adalah bersama-sama dan sendiri-sendiri.</p>
<p>53. The rights and remedies provided in the Agreement will not affect any other rights or remedies available to the Vendor.</p>	<p>53. Hak-hak dan tindakan-tindakan perbaikan yang ditentukan di dalam Perjanjian tidak akan mempengaruhi hak-hak dan tindakan-tindakan perbaikan lain apa pun yang tersedia bagi Penjual.</p>
<p>54. The Agreement cannot be assigned by the Customer without the prior written consent of the Vendor.</p>	<p>54. Perjanjian tidak boleh dialihkan oleh Pelanggan tanpa izin tertulis sebelumnya dari Penjual.</p>
<p>55. Each person signing the Agreement as an authorised officer, agent or attorney of any party by so doing warrants to the other party that, as at the date of signing, he or she has full authority to execute the Agreement on behalf of that party.</p>	<p>55. Masing-masing orang yang menandatangani Perjanjian sebagai pejabat, agen atau kuasa yang berwenang dari pihak yang mana pun dengan berbuat demikian memberikan jaminan kepada pihak lainnya bahwa, pada tanggal penandatanganan, ia memiliki otoritas penuh untuk menandatangani Perjanjian atas nama pihak tersebut.</p>
<p>56. This Agreement may be executed in counterparts ad both counterparts together shall constitute one and the same agreement.</p>	<p>56. Perjanjian ini dapat ditandatangani dalam salinan-salinan dan masing-masing salinan bersama-sama merupakan perjanjian yang satu dan sama.</p>

**SCHEDULE 1
PARTICULARS OF GOODS****LAMPIRAN 1
JENIS BARANG**

Refer to signed GF quotation or Order Confirmation

Mengacu pada Penawaran GF atau Konfirmasi Order

**SCHEDULE 2
RETURN OF GOODS POLICY****LAMPIRAN 2
KEBIJAKAN PENGEMBALIAN BARANG**

No Goods will be accepted by the Vendor for return, exchange or credit unless all the following terms and conditions have been complied with by the Customer:

Tidak ada Barang yang akan diterima oleh Penjual untuk pengembalian, penukaran atau kredit kecuali kalau semua syarat dan ketentuan berikut ini telah dipenuhi oleh Pelanggan:

1. Subject to the terms and conditions of this Agreement and after a return authorisation and return authorisation number has been obtained from the Vendor, at the Vendor's discretion, the following Goods may be accepted for return by the Customer:
 - (a) Goods alleged to be defective in material and/or workmanship; and
 - (b) incorrect type or quantity of Goods contained in each Delivery provided the Customer is within the time limit set out in clause 17 of these Terms.
2. Freight charges for all returns must be prepaid by the Customer at its expense. Cash on Delivery/C.O.D. packages will not be accepted by the Vendor.
3. The Goods must be returned by the Customer to the Vendor's warehouses as directed by the Vendor.
4. Only Goods purchased directly from the Vendor will be accepted for return.
5. The returned Goods are accompanied by a dispatch note stating the return authorisation number, the Vendor's original invoice number, the reason for the return and any other information as may be required by the Vendor.
6. Goods returned by the Customer for other than warranty purposes shall be subject to a restocking charge of twenty-five percent (25%) of the relevant price for the Goods. If the Goods are received by the Vendor in a condition which the Vendor reasonably believes will affect the price or ability to resell, then additional restocking charges may be levied or a credit may be completely denied.

1. Tunduk pada syarat-syarat dan ketentuan-ketentuan Perjanjian ini dan setelah persetujuan pengembalian dan nomor persetujuan pengembalian telah diperoleh dari Penjual, atas kebijakan Penjual, Barang berikut ini boleh diterima untuk pengembalian oleh Pelanggan:
 - (a) Barang yang diduga cacat dalam bahan dan/atau pembuatan; dan
 - (b) Jenis atau jumlah Barang yang tidak benar yang terdapat dalam masing-masing Penyerahan asalkan Pelanggan berada dalam batas waktu yang tercantum di dalam klausul 17 Syarat-syarat ini.
2. Ongkos pengangkutan untuk semua pengembalian harus dibayar terlebih dahulu oleh Pelanggan atas biayanya. Paket-paket Cash on Delivery/C.O.D. (pembayaran dilakukan sewaktu pembayaran diterima) tidak akan diterima oleh Penjual.
3. Barang harus dikembalikan oleh Pelanggan ke gudang Penjual seperti yang diarahkan oleh Penjual.
4. Hanya Barang yang dibeli secara langsung dari Penjual akan diterima untuk pengembalian.
5. Barang yang dikembalikan disertai dengan catatan pengiriman yang menyatakan nomor persetujuan pengembalian, nomor faktur semula Penjual, alasan pengembalian dan informasi lain apa pun seperti yang mungkin diwajibkan oleh Penjual.
6. Barang yang dikembalikan oleh Pelanggan selain untuk tujuan jaminan dikenai biaya penyetokan ulang sebesar dua puluh lima persen (25%) dari harga yang terkait untuk Barang tersebut. Jika Barang diterima oleh Penjual dalam kondisi yang dipercaya secara layak oleh Penjual akan mempengaruhi harga atau kemampuan untuk menjual kembali, maka biaya penyetokan ulang tambahan boleh dibebankan atau kredit boleh ditolak sama sekali.

**SCHEDULE 3
WARRANTY PERIOD****LAMPIRAN 3
PERIODE JAMINAN**

As set out in Clause 32 and 33, The Vendor warrants the Goods free from factory defect for 12 (twelve) months from delivery date.

Seperti tercantum dalam Klausul 32 dan 33, Penjual menjamin Barang bebas dari cacat produksi selama 12 (dua belas) bulan sejak tanggal penyerahan.

Contact Information

PT Georg Fischer Indonesia

Factory

Dusun Sukamulya RT. 019 RW.006
Anggadita Klari,
Kab. Karawang Jawa Barat 41371
Phone: +62 267 432 044
Fax: +62 267 431 857

PT Georg Fischer Trading Indonesia

Head Office

Dusun Sukamulya RT. 019 RW.006
Anggadita Klari,
Kab. Karawang Jawa Barat 41371
Phone: +62 267 432 044
Fax: +62 267 431 857

Sales & Marketing Office

Wisma 77 Tower 2, 5th Floor Zone 2
Jl. S. Parman Kav. 77
11410 Jakarta Barat
Indonesia
Phone: +62 21 2967 6066
Email: indonesia.ps@georgfischer.com
www.gfps.com/id

Branch Office - Surabaya

Jl. Raya Gilang No.33,
Sidoarjo 61257 Jawa Timur
Indonesia
Phone : +62 31 9978 4535
+62 31 9978 4344

Branch Office - Bali

Jl. Raya Cargo (Mahendradatta) No. 63x Kav. B
Pemecutan Kaja, Denpasar Utara, Denpasar – Bali
Indonesia
Phone 1: +62 361 419 642
Phone 2: +62 361 907 7379

The technical data are not binding and not expressly warranted characteristics of the goods.
They are subject to change. Please consult our General Conditions of Supply.



www.gfps.com/id

700.671.635CTLG ID
GFID_FM8905_4f CTLG (09.19)
© Georg Fischer Indonesia

ID-8201 Karawang/Indonesia, 2019